

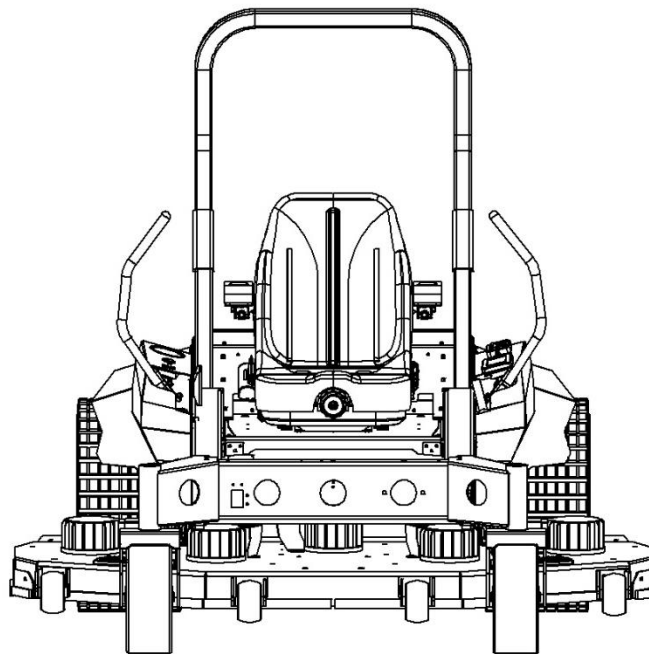

EVO-74" ZTR Operator's Manual



Mean Green Products, LLC
4404 Hamilton Cleves Rd. Ste. 2
Hamilton, OH 45013
513-738-4736 (Sales & Services)
www.meangreenproducts.com

Index

	Page:
General Information	3
Warranty Information	4-6
Warranty Registration	6
Warranty Registration Card	6
Safety Precautions	7
Safety and Instruction Decal	7-13
Touch Screen Display Settings	14-18
High/Low Blades Switch	14-15
Lights On/Off Switch	15
High/Low Drive Speed Control Switch	15
Mower Control Panels	19
PTO Deck Blades ON/OFF Switch	19
Push Button Start	20
Blade Warning Light System	20-22
Drive Control Bars	22
Operation	22-25
Use of ramp	23
Slope Operation	23-25
Slope Guide	25A
Children	26
Safety Interlock System	26
Starting/Stopping Your Mower	26
Driving the Mower	27
Smooth Travel	28
Basic Driving	28
Practice Turning Around Corner	28
Practice Turning in Place	29
Advanced Driving	29
Operating Suggestions	30
Deck Cutting Height Adjustment	31
Anti-Scalp Wheels	32
Towing or Manual Pushing	32
Emergency Drive Brake Release Levers	32-33
Maintenance & Adjustments	33
Service	33-34
Jacking the Mower	34-35
Regular Maintenance	35
Torque Values	35
Tires	35
Lubrication	36
Electrical System	36
Seat Adjustment	36
Seat Release Latch	37
Filter Cleaning	37



Battery Compartment Open/Close Handle & Battery Lock	38
Mower Blade Maintenance	38
Mower Blade Removal	38-39
Mower Blade Installation	39-41
Electrical System Safety	42
Electrical System Information	42
Component Maintenance	42
Battery Safety	42-43
Battery Connectors	43
Battery Maintenance	43
Battery Charging Procedures & Options	43
Battery Chargers	43
Charging Recommendations	43-44
Proper Connection & Disconnection of Charger	44-45
Disconnecting Batteries	46
Battery Storage	46
Troubleshooting	46-47
Storage	47
New Season Preparation	47
Lithium Energy Module Maintenance	48
Seat Belt & ROPS	49



GENERAL INFORMATION

**This manual applies to the following Mean Green Products equipment lines:
Mean Green Mowers – EVO 74" Zero Turn Model**

To the new operator

The purpose of this manual is to assist owners and operators in maintaining and operating the mower. Please read it carefully; information and instructions furnished can help you achieve years of dependable performance. It is the **owner's responsibility** to make certain that the operators and mechanics read and understand this manual and all decals before operating this machine. It is also the **owner's responsibility** to make certain that the operators and mechanics are qualified and physically able individuals, properly trained in the operation of this equipment. All operators and mechanics must become familiar with the safe operation of the equipment, operator controls and safety signs. Never let children or untrained people operate or service the equipment. Local regulations may restrict the age of the operator. The owner/user can prevent and is responsible for accidents or injuries occurring to themselves, other people or property.

Using this manual

General operation, adjustment and maintenance guidance is outlined for both the experienced and novice Mean Green Mower user. Operating conditions vary considerably and cannot all be addressed individually. Through experience, however, operators should find no difficulty in developing good operating skills suitable to most conditions. Directions used in this manual, for example RIGHT or LEFT, refer to directions when seated on the mower/standing facing forward, unless otherwise stated. Photographs and illustrations used were current at the time of printing, but subsequent production changes may cause your machine to vary slightly in detail. **Mean Green Products reserves the right to redesign and change the machine as deemed necessary, without notification. If a change has been made to your machine which is not reflected in this owner's manual, or the parts manual, see your Mean Green Products dealer for current information and parts.**

Warranty registration

The Owner must register the unit by filling out the Warranty Registration Form, provided in the owner's packet, to validate your warranty protection. As the new equipment owner, you are expected to see that this is done at the time of delivery. If using the Warranty Registration Form, it **MUST** be completed and signed by the authorized dealer or original purchaser.

Be sure to register the mower plus each attachment that displays a model and serial identification number plate with Mean Green Products. **IMPORTANT:** Any unauthorized modification, alteration, or use of non-approved attachments voids the warranty and releases Mean Green Products from any liability arising from subsequent use of this equipment.

Model and serial number

The mower serial number is found on the serial identification plate located on the right-side wall behind the operator leg. The model is the type of Mean Green Mower purchased i.e. Rival-60, CXR-52, SK-48 etc. The serial numbers and model are required on the Warranty Registration form. They will also assure you of the correct service parts when replacement becomes necessary.

Parts and service

All warranty repair and service must be handled through an authorized Mean Green Products dealer. Arrangements should be made through your local service center.

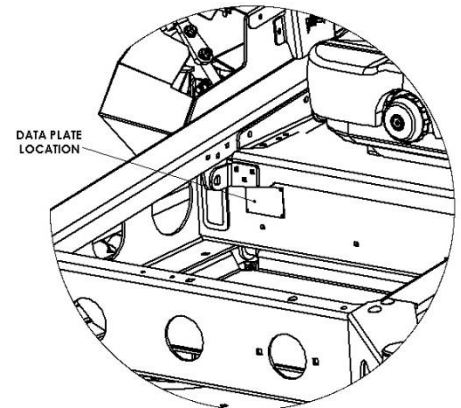

Mean Green Products LLC

3 Year Limited Warranty for Residential and Commercial Use Mowers

WHAT IS COVERED BY THIS WARRANTY?

Mean Green Products, makes the following warranty to the original purchaser of mowers manufactured by Mean Green Products, LLC:

A. Residential Use: Mean Green Mowers used for normal **residential purposes*** are warranted for **two (2) years or 500 hours total usage (whichever comes first) from date of delivery** on all materials and workmanship.

If the Purchaser discovers within this warranty period (two years from date of delivery) a defect in materials or workmanship, he must promptly notify Mean Green Products or an authorized dealer, in writing of the defect.

In no event shall such notification be received by Mean Green Products, or an authorized dealer later than twenty-four (24) months from date of delivery. Within a reasonable time after such notification, Mean Green Products, will correct any defect in material or workmanship on the Mean Green Mower by repairing or replacing part(s) with either new or used replacement parts. Such repair, including parts and labor shall be at the expense of Mean Green Products.

Green Lithium Batteries are warranted for a three (3) year pro-rated limited warranty or 500 hr. usage, whichever comes first to the original owner (**consumer**) only.

1st year 100% Parts and labor

2nd year 100% Parts and labor

3rd year Parts only (cells/BMS)/no labor

NOTE: Failure to properly maintain batteries and keep them from one-half to fully-charged will reduce battery life and will void battery warranty.

Provisions of this limited Green Lithium Batteries warranty shall not apply due to:

Abuse or neglect such as water damage, loose wiring, or rusted or corroded hardware; lack of proper maintenance; damage caused by improper installation of the battery, dismantling of battery, apparent outside force damage, operator not following manual instructions, expired warranty period, neglect, breakage, sub-zero freezing, fire, explosion, wreckage, the addition of any chemical, operation of the battery in an overcharged, or the operation of the battery in an uncharged condition (use after BMS shuts off battery); and a battery charged by systems other than the original equipment type battery charger.

Provisions that constitute Green Lithium Batteries Warranty:

- Battery pack cannot be charged or discharged.
- Under the standard condition for testing, capacity is less than 80% of nominal AH rating in the first year, 70% of nominal AH rating in the 2nd year, 65% of nominal AH rating in 3rd year.
- Liquid leakage.
- Damage to battery pack's case and/or accessories due to conditions caused by the battery.

* **Normal residential purpose means use of product on same lot as your home.** Use at more than one location is considered commercial use, and then the commercial use warranty would apply.

B. Commercial Use: Mean Green Mowers used for commercial and institutional use are warranted for **two (2) years or 1200 hours total usage (whichever comes first) from date of delivery** on all materials and workmanship of chassis and deck structures and **one (1) year or 600 hours total usage (whichever comes first) from date of delivery** on all materials and workmanship. If the Purchaser discovers within this warranty period a defect in materials or workmanship: He must promptly notify Mean Green Products, or an authorized dealer, in writing of the defect. In no event shall such notification be received by Mean Green Products, or an authorized dealer later than twelve to twenty-four (12-24) months from date of delivery (depending on part effected). Within a reasonable time after such notification, Mean Green Products, will correct any defect in material or workmanship on the Mean Green Mower, by repairing or replacing part(s) with either new or used replacement parts. Such repair, including parts and labor shall be at the expense of Mean Green Products.

Green Lithium Batteries are warranted for a three (3) year pro-rated limited warranty or 1200 hr. usage, whichever comes first to the original owner (**commercial**) only.



1st year 100% Parts and labor
2nd year 100% Parts and labor
3rd year 100% Parts only/no labor

NOTE: Failure to properly maintain batteries and keep them from one-half to fully-charged will reduce battery life and will void battery warranty.

Provisions of limited Green Lithium Batteries warranty shall not apply due to:

Abuse or neglect such as water damage, loose wiring, or rusted or corroded hardware; lack of proper maintenance; damage caused by improper installation of the battery, dismantling of battery, apparent outside force damage, operator not following manual instructions, expired warranty period, neglect, breakage, sub-zero freezing, fire, explosion, wreckage, the addition of any chemical, operation of the battery in an overcharged, or the operation of the battery in an uncharged condition (use after BMS shuts off battery); and a battery charged by systems other than the original equipment type battery charger.

Provisions that constitute Green Lithium Batteries Warranty:

- Battery pack cannot be charged or discharged.
- Under the standard condition for testing, capacity is less than 80% of nominal AH rating in the first year, 70% of nominal AH rating in the 2nd year, 65% of nominal AH rating in 3rd year.
- Liquid leakage.
- Damage to battery pack's case and/or accessories due to conditions caused by the battery.

C. Rental Use: Mean Green Mowers and Green Lithium Batteries used in rental applications are **not** covered by warranty.

WHO MUST PERFORM THE WARRANTY SERVICE

All warranty service will be performed by dealers or owner mechanics authorized by Mean Green Products. **Service calls and/or transportation expense** of the product to and from the authorized dealer or owner mechanics for warranty work, will be paid by the owner of the product. For warranty service contact an authorized dealer.

WHAT IS NOT COVERED BY THIS WARRANTY

Mean Green Products, does not warranty:

Some products, components or parts not manufactured by Mean Green Products. Repairs made by unauthorized persons. Damage caused by use of the Mean Green Mower for purposes other than those for which it was designed. Damages caused by disasters such as fire, flood, wind, and lightning. Damages caused by neglect, abuse, abnormal use, improper or unreasonable use, accident, negligence, or misuse such as water damage. Repairs or replacement resulting from the use of unauthorized parts, accessories or attachments. Repairs or replacement as the result if any alterations or modifications, in the determination of the Mean Green Mower, which adversely affects the operation, performance or durability of the equipment. The Mean Green Mower which has the serial number removed or made illegible. Depreciation or damage caused by normal wear, lack of reasonable and proper maintenance, failure to follow the product's owner's manual operating, maintenance and adjustment instructions or other operational instructions provided by Mean Green Products. Normal maintenance parts and service including, but not limited to, lubricants, blades, blade sharpening, bearings, brake or steering adjustments.

DISCLAIMER OF WARRANTY

The foregoing warranties are in lieu of all other warranties, expressed or implied, including but not limited to the implied warranties of merchantability and fitness for a particular purpose. However, if the Mean Green Mower is purchased as a consumer product, any implied warranty of merchantability or fitness for a particular purpose is limited to the duration of this limited warranty. Some states do not allow limitations on how long an implied warranty lasts, so the above limitation may not apply to you. This warranty gives you specific legal rights, and you may also have other rights which vary from state to state.

LIMITATION OF REMEDIES

In no case shall Mean Green Products, be liable for any special, incidental, or consequential damages based upon breach of warranty, breach of contract, negligence, strict liability in tort, or any other legal theory. Such damages include, but are not limited to:

- Loss of profits
- Loss of savings or revenue
- Loss of use of the Mean Green Mower or any associated equipment

- Cost of capital
- Cost of any substitute equipment, facilities, services or downtime
- The claims of third parties including customers, and injury to property

Some states do not allow the exclusion or limitation of incidental or consequential damages, so the above limitation or exclusion may not apply to you.

TIME LIMIT

Any action for breach of warranty must be commenced within twenty-four (24) months following delivery of the goods in a **residential** application. Any action for breach of warranty must be commenced within twelve to twenty-four (12-24) months following delivery of the goods in a **commercial** application.

NO OTHER WARRANTIES

This agreement is understood to be the complete and exclusive agreement between the parties, superseding all prior agreements, oral or written, and all other communications between the parties relating to the subject matter of this agreement.

ALLOCATION OF RISKS

This agreement allocates the risks of product failure between Mean Green Products and the purchaser. This allocation is recognized by both parties and is reflected in the price of the goods.

OWNER'S RESPONSIBILITY

You must maintain your Mean Green Mower following the maintenance procedures described in your owner's manual. Such routine maintenance, whether performed by a dealer or by you, is at your expense.

This machine like any other powered equipment is potentially dangerous unless properly operated. Any operator **must** be cautious and keep safety in mind at all times. Any operator, prior to using the Mean Green Mower, should thoroughly familiarize himself with the owner's manual regarding operation and safety of the machine, as well as all safety warnings on the machine itself.

WARRANTY REGISTRATION

1. **Owners must** register the unit by filling out the Warranty Registration Form, provided in the owner's packet. It **MUST** be completed and signed by the authorized dealer or original purchaser.
2. For validation, the completed Warranty Registration Form **MUST** be forwarded to Mean Green Products, within ten (10) days following date of purchase.
3. The date of purchase constitutes delivery.

www.meangreenproducts.com

4404 Hamilton Cleves Rd * Unit 2
Hamilton, OH 45013
513-738-GREN(4736)



SAFETY PRECAUTIONS



This safety alert symbol is used to call attention to a message intended to provide a reasonable degree of **PERSONAL SAFETY** for operators and other persons during the normal operation and servicing of this equipment.

DANGER (red color) – denotes immediate hazards which WILL result in severe personal injury or death.

WARNING (yellow color) – denotes a hazard or unsafe practice which COULD result in severe personal injury or death. This manual uses two other words to highlight information. **IMPORTANT (blue color)** calls attention to special mechanical information and **NOTE:** emphasizes general information worthy of special attention. All operators and mechanics should read this manual and be instructed about safe operating and maintenance procedures. If the operators or mechanics cannot read and understand English, it is the owner's responsibility to explain this material to them. **However, improper use or maintenance by the operator or owner can result in injury. To reduce the potential for injury, comply with these safety instructions and always pay attention to the safety alert symbol, which means DANGER or WARNING - "personal safety instructions." Failure to comply with the instructions may result in personal injury or death. Incorrect usage of this machine may result in severe injury. Personnel operating and maintaining it should be trained in the proper use and should read the manuals completely and thoroughly before attempting to set-up, operate, adjust, or service this machine.**

It is the **owner's responsibility** to make certain that the operators and mechanics read and understand this manual and all decals before operating this machine. It is also the **owner's responsibility** to make certain that the operators and mechanics are qualified and physically able individuals, properly trained in the operation of this equipment. All operators and mechanics must become familiar with the safe operation of the equipment, operator controls and safety signs. Never let children or untrained people operate or service the equipment. Local regulations may restrict the age of the operator. The owner/user can prevent and is responsible for accidents or injuries occurring to themselves, other people or property. The owner should also ensure that the operator/mechanic know that they are responsible for their own safety as well as the safety of other persons within the vicinity. **Remember**, the operator is responsible for accidents or hazards occurring to other people or their property.

Safety and Instruction Decals

Specific safety warning decals are located on the equipment near the immediate areas of potential hazards. These decals should not be removed or obliterated. Replace them if they become non-readable.

The following illustrations show the various decals that are located on the machine. A brief explanation, for those requiring one, is shown to help the operator understand the meanings of these decals.

• Read Owner's Manual and Safety Warning Decals before attempting to operate this machine.

DECAL INFORMATION

- Safety decals must be visible and clear from foreign matter and debris.
- Decals that have been worn off or have become illegible must be replaced.
- When replacement components are installed be sure that current safety signs are affixed to the replaced components.
- If an attachment or accessory has been installed, make sure current safety signs are visible.
- Replacement decals can be ordered from Mean Green’s main office.
- Expose the adhesive surface by peeling off the back of the decal and placing it onto a clean dry surface.

DECALS

Familiarity of these decals will help in the safe operation of your mower.

MGUPN069



48V Main Power Decal-

Indicates the connection between the battery and the mower.

MGUPN070

Above Seat Pan Decal-



- 1: Read and learn manual before servicing the machine.
 - 2: Disconnect machine from battery before servicing.
 - 3: Electrical shock hazard present.
 - 4: Surfaces may be hot to the touch.
-

MGUPN072

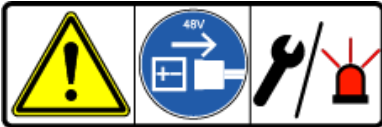

Disconnect Battery-

When performing maintenance or there is an emergency, disconnect the battery from the mower.

MGUPN074

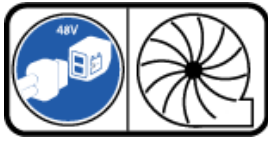

Blower and Charge Port-

This decal indicates where the connector is to alternatively charge the mower or to power the debris blower.

MGUPN075



Charger-

Shows a port that is used for charging the mower.

MGUPN076

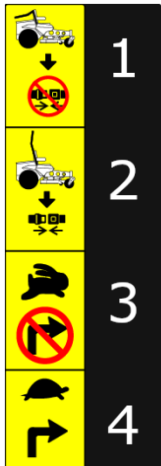

1 Rollover-

1: When the ROPS is down, do not fasten the seatbelt.

2: When the ROPS is up, fasten the seatbelt.

3: Do not take sharp turns at high speeds.

4: Take sharp turns at slow speeds.

MGUPN077



No Riders-

When operating the mower, no person should ride or attempt to ride on the machine to prevent serious injury.

MGUPN078

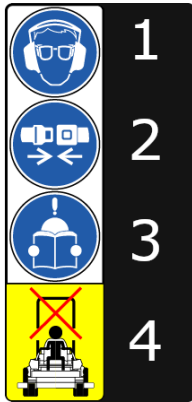

ROPS-

- 1: Wear ear and eye protection when operating the machine.
 - 2: Wear your seatbelt when operating the machine.
 - 3: Read and learn manual.
 - 4: Do not remove the ROPS from the machine.
-

MGUPN079

Electrical Compartment Warnings-



- 1: Attention
 - 2: Surfaces may be hot to the touch.
 - 3: Do not wash the electrical compartment of the mower.
 - 4: Electrical shock hazard.
-

MGUPN080



Patent Decal-

Displays the patent of the mower.

MGUPN234



Jack Decal-

Shows where the jack points are on the mower.

MGUPN235

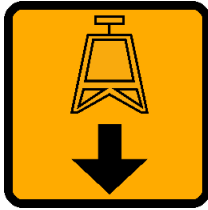

Stand Decal-

Shows areas to place jack stands on the mower.

MGUPN315



Left Control Panel-

1: Read and learn manual before operation.

2: Reference the manual.

MGUPN316



Right Control Panel:

1: Do not mow around other people.

2: Do not let people ride on the machine during operation.

3: Mow with the chute down to prevent debris from injuring people.

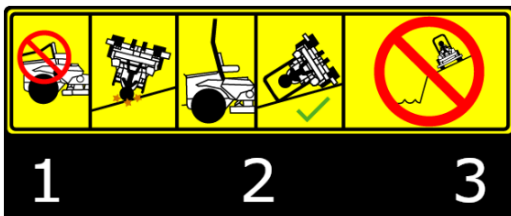

1: Operating the machine with the ROPS down creates an increased risk of death or serious injury.

2: Operating the machine with the ROPS up will protect the operator in the event of a rollover.

3: Do not operate the mower around steep drops or steep hills.



Operating the mower on slopes greater than 20° will potentially cause rollover.

Operate the mower on slopes less than 20° for safe operation.

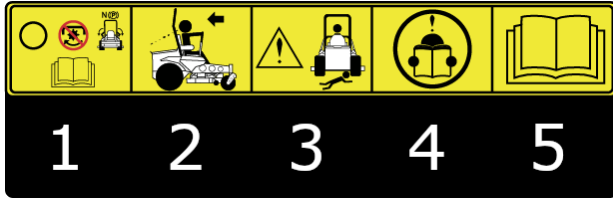

- 1: Shutdown operation procedure: Power off, PTO off, handlebars out.
 - 2: When operating in reverse, remember to look behind for any objects or obstacles.
 - 3: Watch out for small children that may be around the machine during operation.
 - 4: Read and learn the manual before operation of the machine.
 - 5: Read manual for further information.
-

MGUPN317



Right Front Control Panel-

Move the control handles forward to move the machine forward, and move the control handles backwards to go in reverse. To engage neutral lock, push out on the control handles.

MGUPN318



Left Front Control Panel-

Move the control handles forward to move the machine forward and move the control handles backwards to go in reverse. To engage neutral lock, push out on the control handles.

MGUPN328

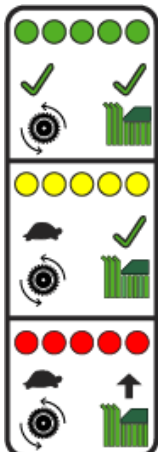

Blade Light-

If lights are green, then the drive speed and deck height are good.

If lights are yellow, slow down drive speed.

If lights are red, slow down drive speed and raise deck.

MGUPN346

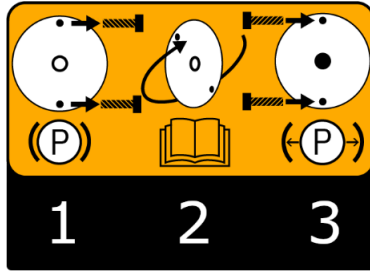

Parking Brake- Manual Disengage

1: When the extrusion is facing out, the parking brake is engaged. Remove the bolts to release the parking brake plate from the drive.

2: Flip the parking brake plate and bolt back on drive to disengage parking brake.

MGUPN360

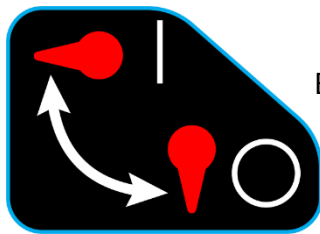

Battery Power ON and OFF-

When the switch is horizontal, the battery power is on.

When the switch is pointing down, the battery power is off.

MGUPN362

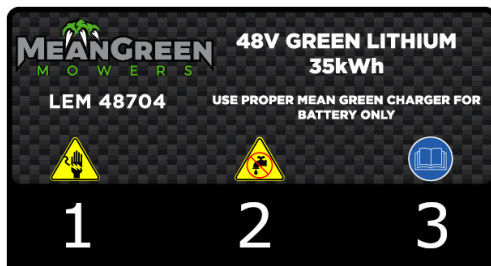

Battery Decal-

Displays information about the battery pack in the mower.

1: Electrical shock hazard.

2: Do not wash the battery.

3: Read the manual before handling or servicing the battery.

MGUPN368



Fan Information-

Displays information about the fan and routine maintenance for the fan.

⚠ Important: Touch Screen Display Settings

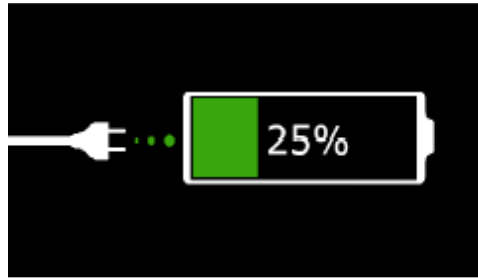

Charging Screen

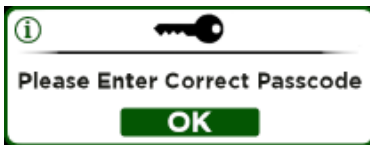

Wrong Passcode Pop-up



Reset Passcode Pop-up

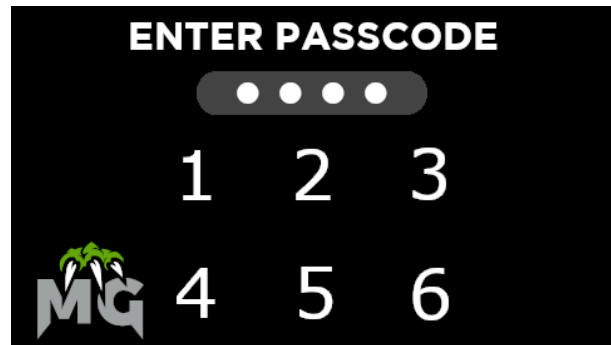

Lock Screen/Pass-code

Touch Screen Home Page Display (fig.2A)

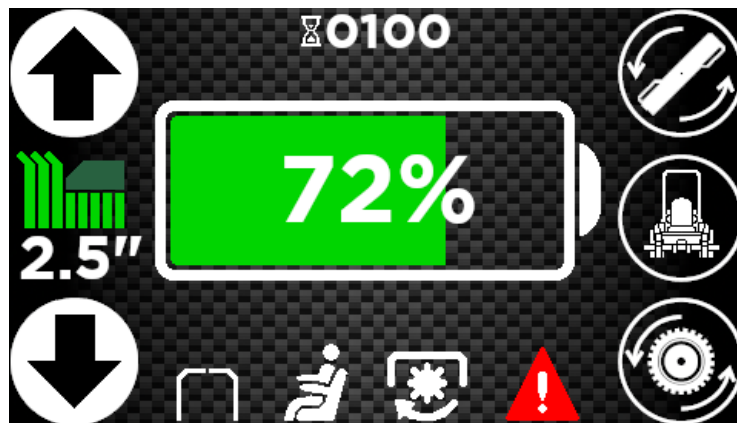

Fig.2A

Fig.2B & 2C: Hi/Low Blades Switch: High Blade Mode is higher blade speed for cutting thicker grass. Low Blade Mode provides lower blade speed used for lower battery consumption on thinner dry grass areas. NOTE: Mowing time may be increased up to 15% when mowing in low blade mode when practical.



Blade Speed HIGH
Fig.2B



Blade Speed LOW
Fig.2C

Fig.2D & 2E: *Optional* Lights Switch: Turns headlight On and Off when additional light is needed. (Located on display mower application battery page)



Light OFF
Fig.2D



Light ON
Fig.2E

Fig.2F & 2G: **Drive Speed Control Switch** – Allows operator to select a comfortable driving speed Low or High depending on terrain, grass conditions, slope, operator experience etc. Push button for Lowest, Slow Speed for inexperienced operators, for trimming around objects, buildings and other obstacles. Always **EASY DOES IT** when unsure or new user to the equipment! Get comfortable with mower before pushing button into HIGH speed!



Drive Speed HIGH
Fig.2F



Drive Speed LOW
Fig.2G



Seat Occupied



Seat Unoccupied



Deck Height
On touch screen display, control height of deck and set to desired height on display screen.

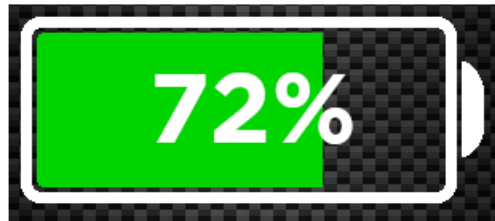

State of Charge



Hour meter



DTC Fault Notification



Mower Application

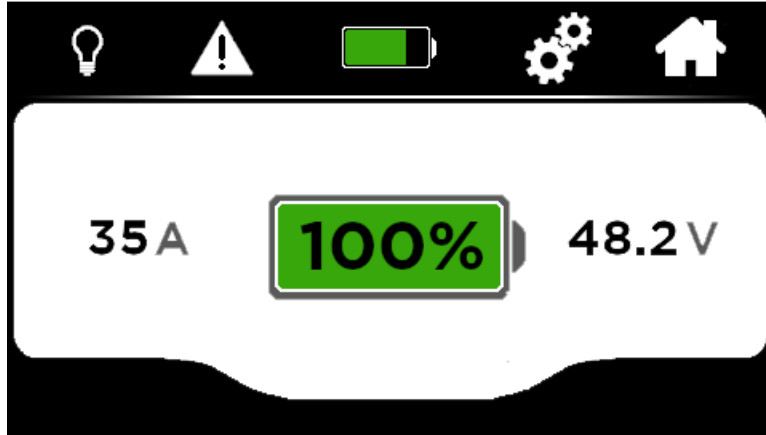

Battery Screen

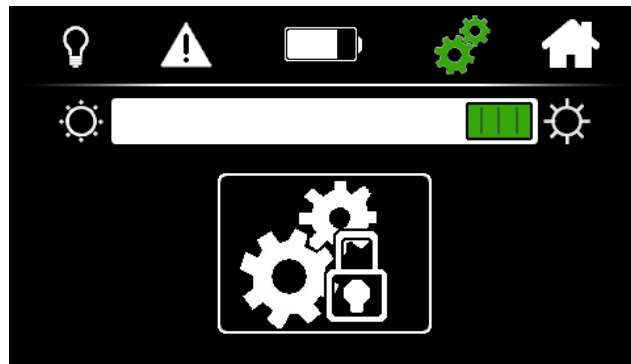

Setting Screen

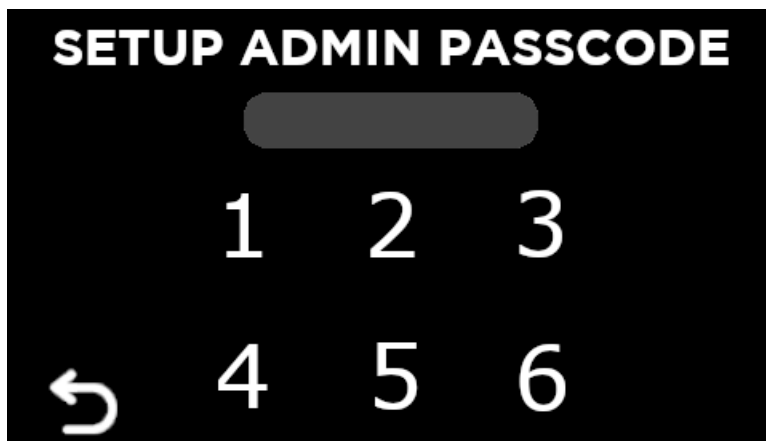

Setup Admin Passcode

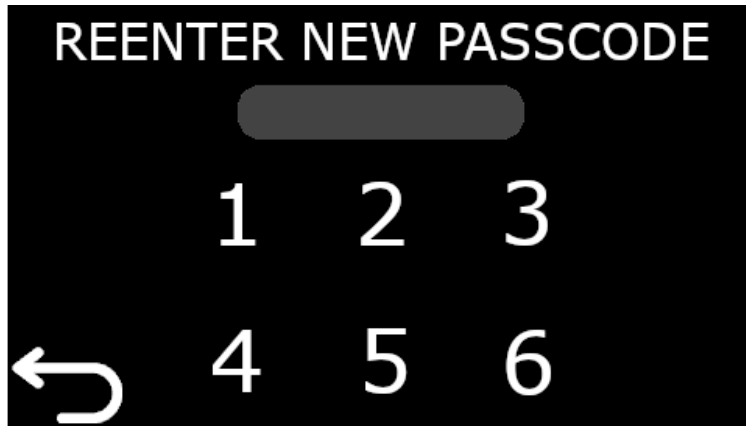

Reenter Admin Passcode

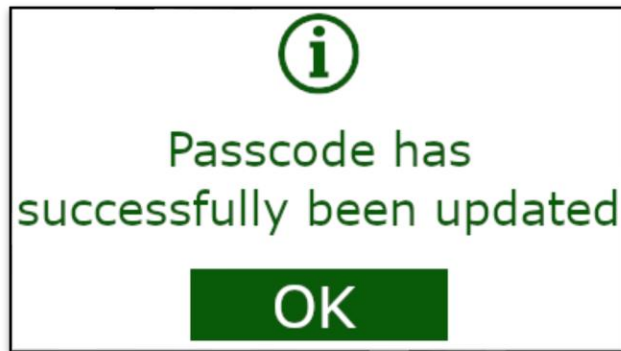

Passcode Change Success



Brightness Slider



Admin Setting Icon

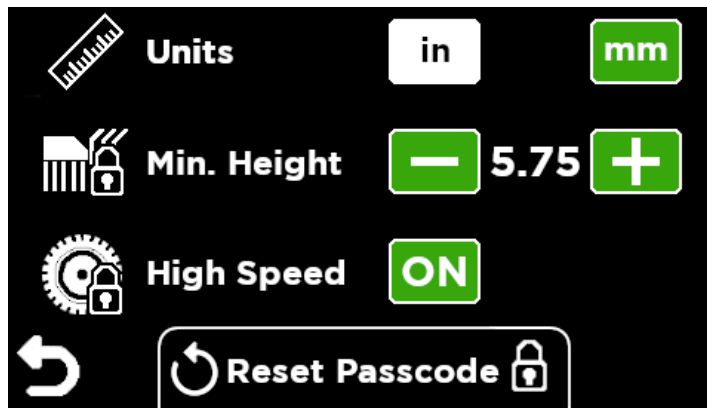

Admin Setting Screen



Units: Inches or Millimeters



Min Deck Height



High Speed Feature



Feature ON



Feature OFF

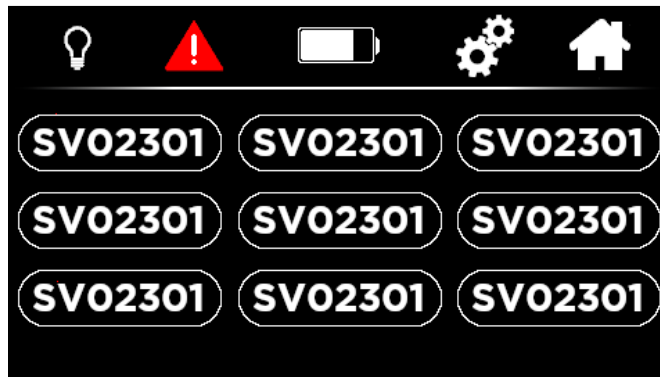

Active DTC Screen



DTC Pop-up Screen

Right Side Mower Control Panel (With Operator Seated)

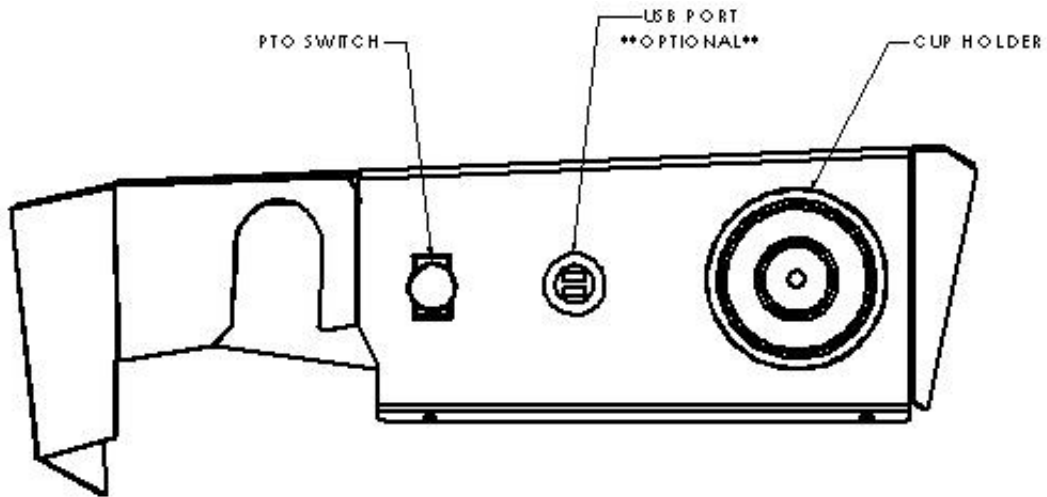

Fig.2

Fig.2: PTO Deck Blades ON and OFF Switch: This switch engages the deck blade motors. Pull the switch up to engage blades and push switch down to disengage blade motors. **NOTE: There may be a few second delay before blades will start!**

Fig.2: Optional USB Port for convenient use of electronics.

Left Side Mower Control Panel (With Operator Seated)

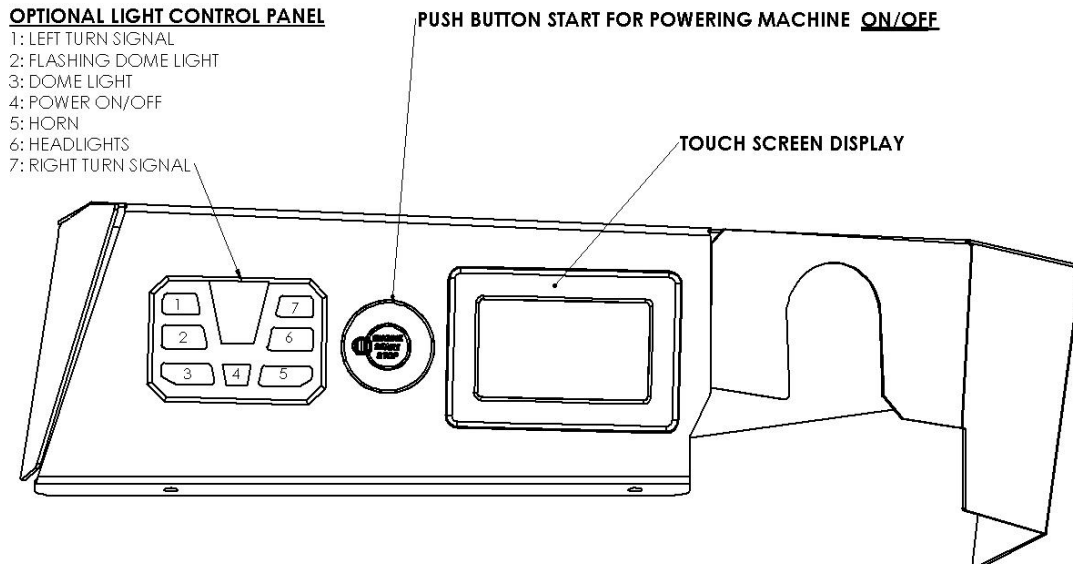

Fig. 3

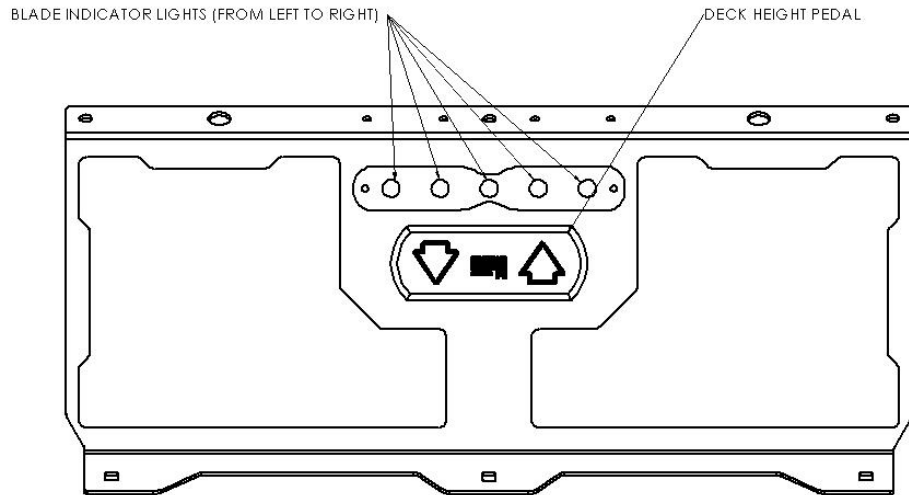

Fig. 5

GREEN: Maintain Speed and Height.

YELLOW: Reduce Speed or Raise Deck Slightly.

RED: Slow Speed and Raise Deck Slightly

****Ensure Inner Deck Is Clear and Blades Are Sharp Before Each Use!!**

Blade Warning Light System:

A 3 light system to assist operator with optimal mowing performance in all grass conditions showing speed and performance of each blade. **NOTE:** Allow up to 10 seconds for the blade lights to turn on after blades are engaged. (Operator can start mowing grass before lights are on.) The lights run in order of the blades – for example, the left light is monitoring the left blade, center light is monitoring center blade and right light is monitoring right blade. Once lights are on, operator should see solid GREEN. This will indicate the blades are running at full speed and optimal power.

GREEN Light: Operator can maintain drive speed and the cutting height is accurate for optimal performance. As the operator enters thicker grass, a light or lights (depending on which blade is cutting the thickest grass) will be YELLOW. If this occurs, it is best to slow drive speed and allow blades to return to GREEN. If slowing drive speed does not return lights to GREEN, operator may need to slightly raise the deck to return to GREEN and an optimal cutting performance. A ¼ inch rise in the deck can make a huge difference in cut quality and cutting speed especially in tall, wet grass.

YELLOW Light: Reduce drive speed. Operator may need to raise the deck ¼ inch to keep the deck at optimal power and blade performance. If the operator continues to run the mower in YELLOW with longer, taller, wet grass, the lights will turn RED. RED lights indicate the blade tip speed and power is at the lowest point and is on the verge of shutting down. Continuing to run in RED will result in your blade or blades shutting down completely, requiring the operator to turn Deck Blades Off push control bars out to reset before engaging PTO switch. **TO AVOID THE BLADES SHUTTING OFF- SLOW DOWN AND RAISE DECK SLIGHTLY!** This means the grass is too tall, thick or wet and may need recut in this area for optimal performance.

RED Light: Slow drive speed. Raise deck. You may need to look at double cutting area if grass is too tall or thick.

NOTE: Once the blade/blades have shut down, the red light will go to a blinking green light or turn off. This will inform the operator that a blade/blades have shut off and will need reset by turning Deck Blades Switch Off, push the control bars out to reset before engaging PTO switch.

Fig. 6: Drive Control Bars –

To DRIVE MOWER FORWARD, push right & left Drive Control Bars forward an equal distance.

To DRIVE MOWER IN REVERSE, pull right & left Drive Control Bars rearward an equal distance.

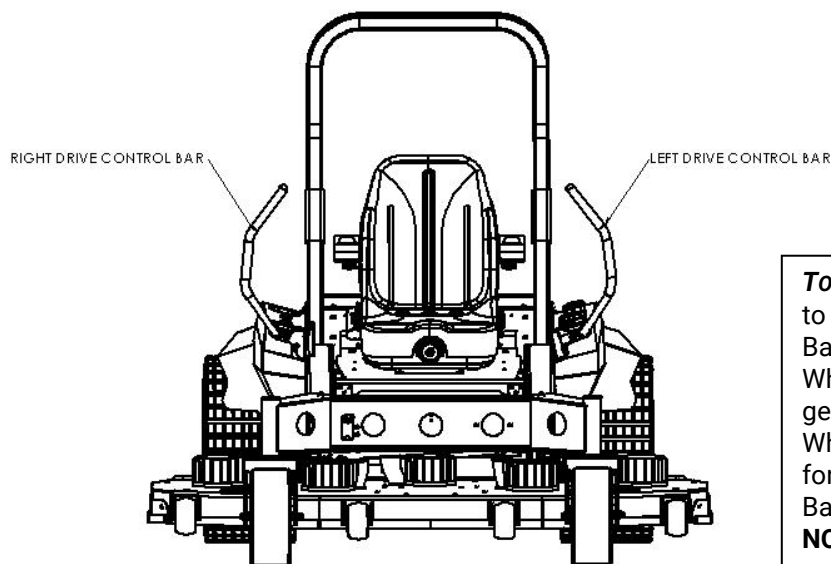

To STOP, move right & left Drive Control Bars to neutral, **middle** position and push Bars **OUTWARD** into the neutral slots. When going forward to slow down, pull back gently on both Drive Control Bars. When going in reverse to slow down, push forward gently on right & left Drive Control Bars.
NOTE: Always remember middle is neutral!

Fig. 6

OPERATION

Safe Operating Practices

This product is capable of amputating hands and feet and throwing objects. Always follow all safety instructions to avoid serious injury or death.

Operation

Evaluate the terrain to determine what accessories and attachments are needed to properly and safely perform the job. Only use accessories and attachments approved by the manufacturer. Clean battery compartment, drive motor compartment, mower deck, seat etc. of all dirt and debris. Keep unit free of grass clippings, leaves and other debris. **DO NOT** spray under seat or electric components with water to clean unit. Do not use, solvents, hard cleaners or abrasives. Wear adequate eye and hearing protection when cleaning the unit. Never leave a running machine unattended. Always stop on level ground, disengage deck blade switch, place drive control bars in neutral position, turn mower to off position, and turn the battery disconnect to the OFF position for any reason including emptying the catcher or unclogging the chute. Always remain seated while operating machine. (riding mower models) Always keep safety shields and covers in place. Always maintain a safe distance from people and pets when mowing. Always stop machine if someone enters the area. Avoid injury. Keep area clear of bystanders when engaging deck blade switch. Always operate machine in daylight or with adequate working lights. Follow daily and weekly checklists, making sure electrical connections are secured and bolts are tightened. Always observe traffic

laws while driving machine from one location to another. Watch for traffic when operating near or crossing roadways.

Always be alert for hazards such as rocks, metal objects and other debris which may be thrown or entangled by mower blades. Watch out for holes or deep depressions. Inspect area to be mowed for hazards such as rocks, metal objects and other debris which may be thrown or entangled by mower blades. Remove these objects before mowing. Always inspect machine for damage after striking a foreign object. If damage is found, repair machine immediately. Be sure to stop on level ground, disengage deck blade switch, place drive control bars in neutral position, turn mower to OFF position, and turn the battery disconnect to the OFF position! Always wear adequate ear protection, such as earplugs, when operating this equipment as prolonged exposure to uncomfortable or loud noises can cause impairment or loss of hearing. Do not wear radios or music headphones while operating the machinery. Safe operation requires your full attention. Do not operate the equipment while wearing sandals, tennis shoes, sneakers, shorts or any type of loose-fitting clothing. Long hair, loose clothing or jewelry may get tangled in moving parts. Always wear long pants, safety glasses, ear protection and safety shoes when operating this machine. Always wear safety goggles or safety glasses with side shields when operating the mower.

Always be aware of what is behind the machine before backing up. Do not mow in reverse unless absolutely necessary. Always look down and behind before and while backing up. When moving in reverse, **SLOWLY** pull right and left Drive Control Bars rearward and avoid sudden movement. Rapid movement of the Drive Control Bars in either direction could result in a reaction of the machine that can cause serious injury.

Never operate a poorly maintained machine. Never attempt high speed maneuvering, especially in crowded, congested areas or on slopes. Never allow persons to operate this machine without proper instruction or allow children to operate machine. Allow only responsible adults who have read and understand these instructions to operate this machine. Never put hands or feet under any part of the machine while it is running. Never carry passengers.

Never direct discharged material toward anyone. Avoid discharging material against a wall or obstruction. Material may ricochet back toward the operator. Always disengage the blades and wait for them to stop before crossing gravel drives, walks or roads. Always keep clear of the mower blades and attachments during their operation. Turn off blades when not mowing. Slow down before turning.

Turn the battery disconnect to the OFF position before removing the grass catcher or unclogging the discharge chute. Never clear the discharge chute with the machine running. Turn mower OFF, turn the battery disconnect to the OFF position, and make sure the blades have stopped before cleaning. Use a stick to clear a plugged discharge area. **DO NOT use your hand!**

Do not operate the machine while under the influence of alcohol or drugs. Exercise caution when loading or unloading the machine onto a trailer or truck. Data indicates that operators, age 60 years and above, are involved in a large percentage of mower-related injuries. These operators should evaluate their ability to operate the mower safely enough to protect themselves and others from serious injury. If any attachment or additional weight is mounted on the rear or side of the unit (depending on model), any rapid movement in either direction could result in a reaction of the machine that can cause serious injury.

Clean flammable material from machine. Prevent fires by keeping battery compartment, motor compartment, deck and operator's station clean of accumulated trash, grass clippings, and other debris.

Using a ramp

Use extreme caution when loading and unloading a unit onto a truck or trailer with a ramp. Use only a single, full width ramp; do not use individual ramps for each side of the unit. Having a full width ramp provides a surface for the mower frame to contact if the unit starts to tip backwards. It also reduces the risk of a wheel going off and the machine tipping over. Do not exceed a 20-degree angle between the ramp and the ground or between the ramp and the trailer or truck. When on a ramp avoid sudden acceleration.

Slope operation (see page 25A)

Slopes are a major factor in loss-of-control and tip-over accidents, which can result in severe injury or death. All slopes require extra caution. If you cannot back up the slope or if you feel uneasy on it; do not mow it. REMINDER: Only operate on slopes of 20 degrees or less.

Use extreme caution when operating on slopes.

- Be extremely careful changing directions on a slope. Slow down.
- Do not operate where the machine could slip or tip.
- Turn slowly
- Turn on the most level part of the slope
- To maximize traction, it is better to turn the front of the machine uphill, rather than downhill. **If drive tires lose traction, steering control is lost which could cause serious injury or death.**
- If it becomes necessary to turn downhill, turn slowly and gradually.

Do not remove or modify the stabilizer wheels. Watch for holes, ruts, bumps, rocks or other hidden objects. Uneven terrain could overturn the machine. Tall grass can hide obstacles. Remove obstacles such as rocks, tree limbs, etc. Keep all movement on slopes slow and gradual.

Do not make sudden changes in speed or direction. Avoid starting and stopping on a slope. If tires lose traction, disengage the blades and proceed slowly straight down the slope. Mow a safe distance (minimum of 10 feet, 3.05 meters) away from drop-offs, retaining walls, drainage ditches, embankments, water, and other types of hazards to avoid a wheel dropping over the edge or to avoid the ground from breaking away. This will reduce the risk of the machine suddenly rolling over causing serious injury or death. Use a walk behind, push mower or hand-held trimmer on slopes and near drop-offs, retaining walls, drainage ditches, embankments and water to avoid machine rollover and serious injury or death.

Do not mow on wet grass. Reduced traction could cause sliding and loss of steering control.

Do not tow on slopes. The weight of the towed equipment may cause loss of traction and control.

Do not try to stabilize the machine by putting your foot on the ground. If the mower's tires lose traction when operating on slopes, disengage the deck blade switch, place the drive control bars in the neutral position, ensure engagement of emergency brake, turn the mower to the OFF position and get help. Never make sudden starts, stops, turns, or reverse direction, especially when maneuvering on slopes. The steering is designed for sensitive response. Rapid movement of the steering control levers in either direction could result in a reaction of the machine that can cause serious injury.

Never stop suddenly while backing down slopes. This action may result in a reaction of the machine that can cause serious physical injury. The Mean Green Mower is capable of operating horizontally (traverse) on moderate slopes. When operating on slopes up to 20 degrees, be aware of any conditions that may cause the mower drive tires to lose traction resulting in a possible loss of control of the machine. An operator should not operate on a slope until he is thoroughly familiar with the equipment.

Do not operate on slopes greater than 20 degrees.

Refer to Slope Guide, page 25A when determining the degree of slope to be mowed. It is strongly recommended that the operator drive the machine off of the slope, using extreme caution, if any sign of loss of traction is detected. Wait until the condition that caused the problem is resolved before attempting to operate on the slope again. Terrain conditions can affect traction resulting in possible loss of control of the machine. Some of the conditions to be aware of are:

1. Wet terrain
2. Depressions in the ground; i.e. holes, ruts, washouts
3. Mounds of dirt
4. Soil type; i.e. sand, loose dirt, gravel, clay
5. Grass type, density, and height
6. Extremely dry conditions of grass
7. Tire pressure

The attachments mounted to the mower will also affect the way it handles on a slope. Be aware that each attachment's characteristics vary. Another consideration is to always mow a safe distance (minimum of 10 feet 3.05 meters) away from drop-offs, retaining walls, drainage ditches, embankments, water, and other types of hazards to avoid a wheel dropping over the edge or to avoid the ground from breaking away and always be aware of what is located at the bottom of the slope. This will reduce the risk of the machine suddenly rolling over causing serious injury or death. Extreme caution should be used when there is a hazard located at the bottom of the slope. Some examples are:

1. Water; i.e. lake, river
2. Cliffs, retaining walls
3. Roads, highways

4. Buildings

5. Rocks

These are just a few examples of situations when caution must be used when operating on a slope. There are many other possibilities too numerous to mention. Just remember to always exercise extreme caution when operating on any slope.

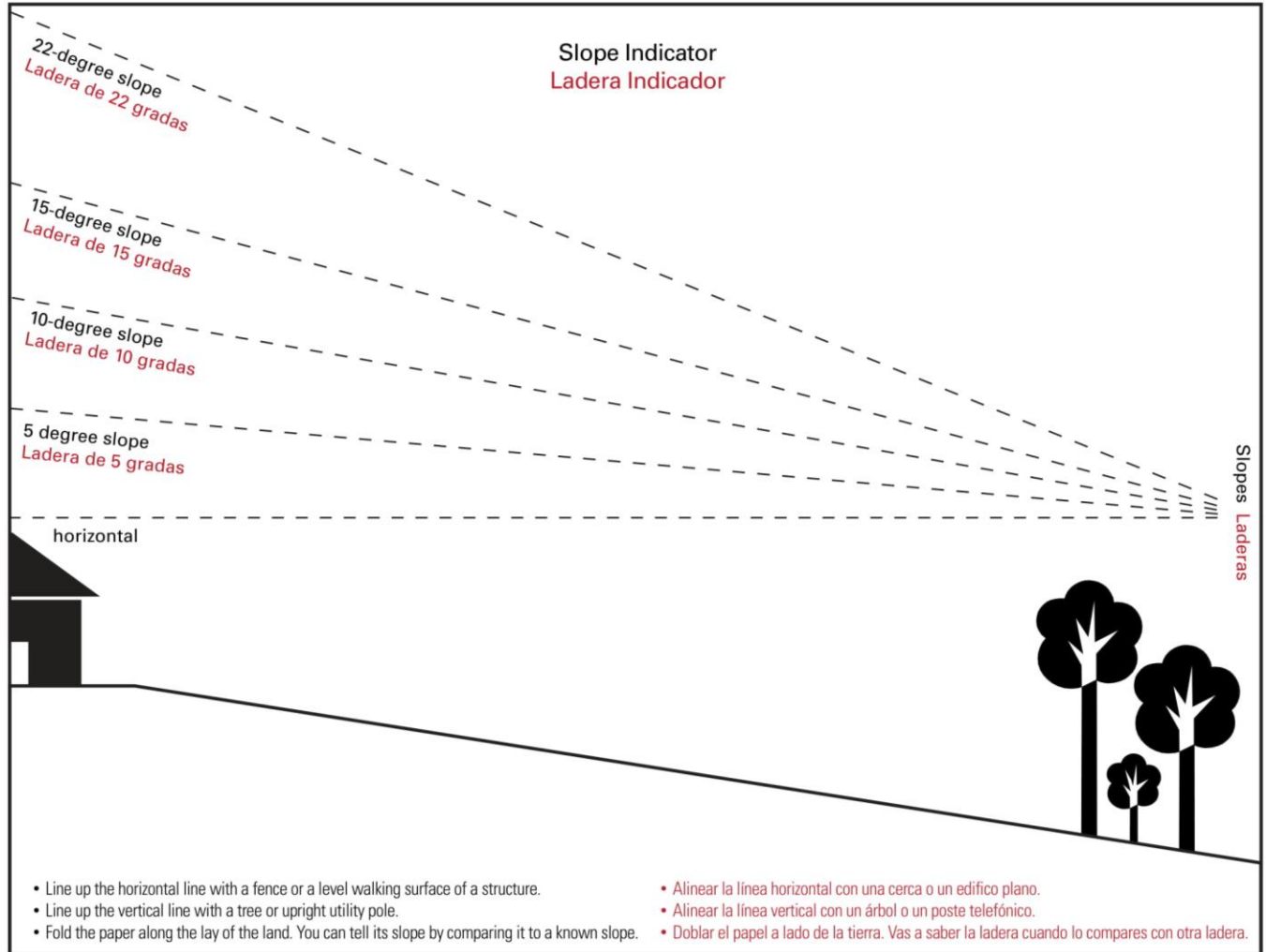

Fig.25A

Children

Tragic accidents can occur if the operator is not alert to the presence of children. Children are often attracted to the machine and the mowing activity. Never assume that children will remain where you last saw them.

Never leave machine unattended while mower is on, especially with children present. Children or bystanders may be injured if they move or attempt to operate the machine while it is unattended. Always disengage deck blades & turn mower to OFF position. Keep children out of the mowing area and under the watchful care of a responsible adult other than the operator. Be alert and turn the machine off if children enter the area. Before and while backing, look behind and down for small children. Never carry children, even with the blades off. They may fall off and be seriously injured or interfere with safe machine operation. Children who have been given rides in the past may suddenly appear in the mowing area for another ride and be run over or backed over by the machine. Never allow children to operate the machine. Use care when approaching blind corners, shrubs, trees, the end of a fence or other objects that may obscure vision. Never allow children or others in or on towed equipment.

Safety start interlock system

The machine is equipped with a safety start interlock system consisting of the park brake switches, seat switch, and deck blade switch. **Check mower safety start interlock system daily, prior to operation.** This system is an important mower safety feature. It should be repaired immediately if it malfunctions. Call a Mean Green Dealer immediately! The machine incorporates a separate seat switch which will stop the drive system and deck motors when the operator is unseated for any reason while the mower is operating. This is a safety feature designed to prevent runaway or accidental entanglement.

To inspect the system:

1. The operator must be on the seat when testing the seat switch.
2. Press push button start to turn machine on.
3. Keep Drive Control Bars in neutral position.
4. Press Deck Blades to ON position.
5. Slowly raise off of the seat. **The deck blade system should stop.**
6. **If the deck blade system fails to stop when the operator is off of the seat and if the cause cannot be determined, contact your Mean Green Products' Dealer immediately.**

Starting your mower:

1. Press push button start ON then type in passcode.
2. Check for the appropriate speed mode by switching High/Low Drive Speed Switch to LOW position. **NOTE: It is always recommended to start out in low mode/ slow speed.**
3. Pull Right and Left Drive Control Bars inward until stops are contacted.
4. Pull up on PTO Deck Blades On/Off Switch to start cutting blades for mowing.
**NOTE: ONLY engage blades when Drive Control Bars are in the NEUTRAL position!
NEVER engage blades when moving!!**
5. Push Drive Control Bars Forward for forward motion and pull rearward for reverse motion. Electric Brake will engage .5 seconds after both Drive Control Bars are returned to neutral.

Stopping your mower:

1. Return Drive Control Bars to the Neutral/Stop position.
2. Push down on Deck Blades On/Off Switch to turn OFF the blades.
3. Push Drive Control Bars outward into the neutral slots. After .5 seconds brakes will engage.
4. Push button to the OFF position.

NOTE: If operator leaves seat with mower in the ON position, the unit may need RESET by pressing the push button start from OFF/ON.

Driving the mower



DANGER: Never make sudden stops or reverse direction, especially when maneuvering on a slope. The steering is designed for SENSITIVE response. Rapid movement of the steering control levers in either direction could result in a reaction of the machine that can cause serious injury.



WARNING: Make sure seat pan is securely locked in place down prior to each use to prevent seat from moving/tilting in the event of mower tipping or rollover.

After turning push button start to ON position:

To go forward, push both Drive Control Bars forward an equal distance

To go in reverse, pull both Drive Control Bars rearward an equal distance

To turn left, move the right Drive Control Bar farther forward from neutral than the left Drive Control Bar.

To turn right, move the left Drive Control Bar farther forward from neutral than the right Drive Control Bar.

Zero radius turn, move one Drive Control Bar forward and the other Drive Control Bar back of neutral. This will allow the drive wheels to counter-rotate.

To stop or decrease speed: To stop, move both Drive Control Bars to neutral, middle position and push levers **OUTWARD** into the neutral slots. When going forward and want to decrease speed, pull back gently on both Drive Control Bars. When going in reverse and want to decrease speed, push forward gently on Drive Control Bars.

For an emergency stop:

When traveling forward or rearward, place the Drive Control Bars in the neutral middle position and push levers **OUTWARD** into neutral slots – this will engage mower safety brakes. Any sudden movement could cause the front of the mower to come off of the ground resulting in possible loss of control causing serious injury or death. Turn the master push button to the OFF position. This will shut down the traction drive system and the deck blade system.



WARNING: Always be aware of what is behind the machine before backing up. Do not mow in reverse unless absolutely necessary. Always look down and behind before and while backing up. **IMPORTANT:** Rapid movement of Drive Control Bars is not recommended as damage to the electric system components may occur.

To increase speed, increase the Drive Control Bars distance from neutral. The farther forward the Drive Control Bars are from neutral, the faster the machine will travel forward. The farther back the Drive Control Bars are from neutral, the faster the machine will go in reverse. Also changing the Drive Speed Control Switch from Low to High will increase or decrease the speeds of mower in forward, reverse and turning.

SMOOTH TRAVEL

The lever controls of the Zero Turn are responsive!

The BEST method of handling the ground speed control levers is in three steps – as shown in Figure 11.

FIRST place your hands onto the levers as shown.

SECOND, to go forward gradually push the levers forward with your palms.

THIRD, to speed up move the levers farther forward. To slow down smoothly, slowly move the levers toward neutral.

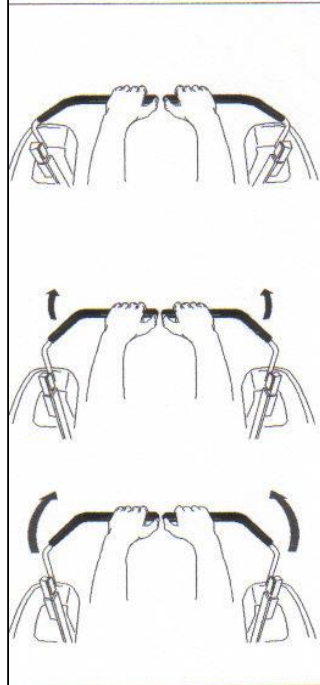

Figure 11. Move Control Levers Gradually

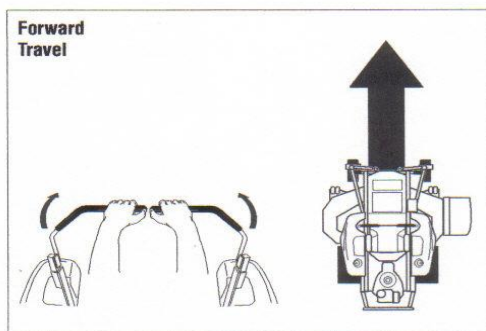

Figure 12. Forward Travel

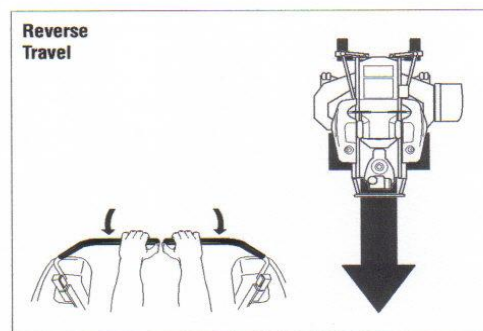

Figure 13. Reverse Travel

BASIC DRIVING

Forward Travel Practice

Gradually move both Drive Control Bars – evenly FORWARD from neutral. Slow down & repeat. Fig.12

Reverse Travel Practice

LOOK DOWN AND BEHIND, then gradually move both Drive Control Bars evenly BACK from Neutral. Fig. 13

PRACTICE TURNING AROUND A CORNER

While traveling forward bring one handle bar gradually back toward neutral. Repeat several times. NOTE: To prevent pivoting directly on the tire tread, it is best to keep both wheels going at least slightly forward.

PRACTICE TURNING IN PLACE

To turn in place, "Zero Turn", gradually move one handle bar forward from neutral and one handle bar back from neutral simultaneously. Repeat several times. NOTE: Changing the amount each lever is pulled – forward or back, changes the 'pivot point' you turn on.

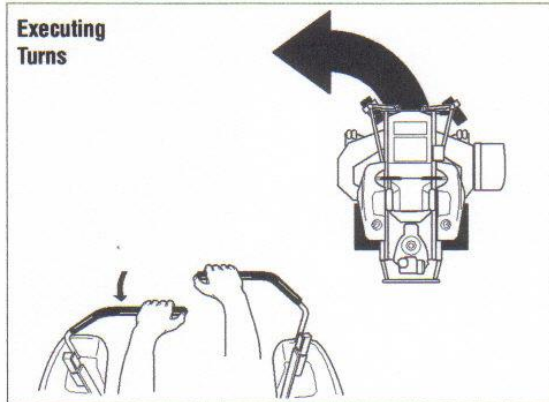

Figure 14. Turning Around a Corner

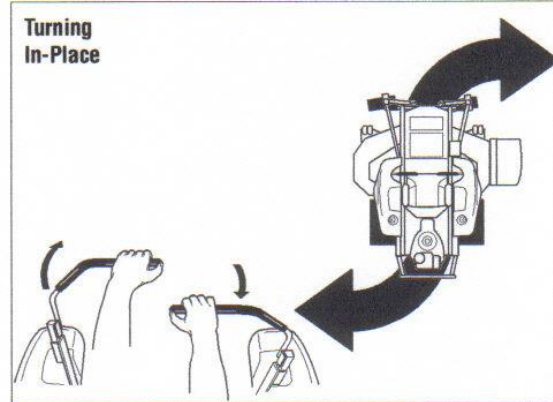

Figure 15. Turning in Place

Advanced Driving

EXECUTING AN END-OF ROW ZERO TURN

Your Zero Turn Mower's unique ability to turn in place allows you to turn around at the end of a cutting row rather than having to stop and Y-turn before starting a new row.

To execute a left end-of row zero turn:

1. Slow down at the end of the row.
2. Move the RIGHT handle bar lever forward slightly while moving the LEFT handle bar lever back to center and then slightly back from center.
3. Begin mowing forward again.

THIS TECHNIQUE TURNS THE RIDER LEFT AND SLIGHTLY OVERLAPS THE ROW JUST CUT – ELIMINATING THE NEED TO BACK UP AND RE-CUT MISSED GRASS.

Remember: The more you practice, the better your control of the zero-turn mower!

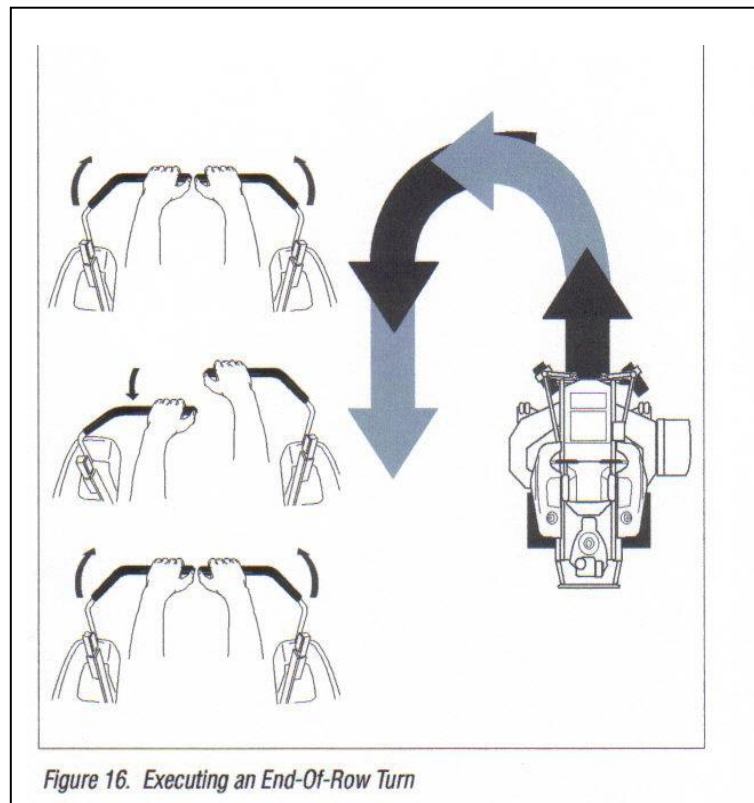





Figure 16. Executing an End-Of-Row Turn

Operating suggestions

 **DANGER:** Prior to operating the mower the operator should be thoroughly familiar with the proper use and operation of the equipment, should read the manual completely and thoroughly, and should have attempted slow moving maneuvers to become familiar with the operation of the equipment before attempting normal speed operation. An inexperienced operator should not mow on slopes or on uneven terrain and should always mow in Slow Drive Speed.

 **WARNING:** If you lose steering control while operating the machine on a slope, TURN BLADES OFF, return Steering Control Bars to NEUTRAL position for brakes to engage, and TURN mower to OFF position. Call your Mean Green Products dealer to resolve problem before continuing to operate.

 **WARNING:** The unit's steering control bars are very responsive: **Easy does it!** For smooth operation, move controls slowly, avoid sudden movement. Skill and ease of operation come with practice and experience. The machine can spin very rapidly. Use caution when making turns and slow down before making sharp turns. **Inexperienced operators may have a tendency to over-steer and lose control.** Slow-moving, slow speed practice maneuvers are recommended to become familiar with these characteristics before attempting high speed operation.

 **WARNING:** Sharp depressions or raised obstacles (such as gutters or curbs) should not be directly approached at high speed in an attempt to "jump" them as the operator could be thrown from the equipment. Approach at a slow speed and angle one drive wheel at the obstruction. Continue at an angle until the wheel clears and then pivot the opposite wheel around. When turning on soft wet turf, keep both wheels rolling either forward or backward. Pivoting on one stopped wheel can damage turf. This is especially important when mowing. **Keep blades sharp.** Many professional mowing companies have additional sets of blades and change blades twice a day: once in the morning and again at noon. **Many problems** with incorrect cutting patterns **are due to dull blades** or blades which have been **sharpened incorrectly.** Information on sharpening blades is listed in this manual's maintenance section. In addition, most communities have individuals or companies which specialize in sharpening mower blades. **Blade sharpness should be checked daily.**

 **DANGER:** Never work with blades while mower is on. Always place deck blade switch in the **disengaged** position, place steering control bars in the neutral position and turn mower to the OFF position and turn the battery disconnect to the OFF position! Block up mower when you **must** work under it. Wear gloves when handling blades. **Always check for blade damage** if mower strikes a rock, a branch or another foreign object during mowing!

Direct grass discharge to right (with side discharge models), away from un-mown area. Select a mowing pattern that directs grass discharge towards the outside, not towards center, of mowing area. Generally, this means using a pattern utilizing **left turns** because side discharge is to **right**. In any case, avoid throwing grass discharge onto un-mowed area because grass is then mowed "twice". Mowing twice puts an unnecessary load on the unit and reduces mowing efficiency.

When mowing a lawn for the first time cut grass slightly longer than normal to avoid scalping uneven terrain. When possible, it is best to use the cutting height that was used in the past. When cutting grass taller than six inches, you may want to mow the lawn twice to achieve a better quality of cut.

During normal mowing cut only about 1/3 of the grass blade. Cutting more than that is not recommended unless grass is sparse or it is the end of the mowing season.

Alternate mowing direction to keep the grass growing straight and better dispersion of the clippings.

Remember, grass grows at different rates at different time of the year. Mow more often in the early spring to maintain the same cutting height. As the growth rate slows in mid-summer, mow less frequently. If you cannot mow at a regular interval, mow at a high cutting height; then mow again two days later at a lower cutting height.

Raise the cutting height of the mower if the cutting width of the mower is wider than the previous mower. This ensures that uneven turf is not cut too short.

Raise the cutting height of the mower if the grass is slightly taller than normal or if it contains a high degree of moisture. Then mow it again with the cutting height set lower.

Deck cutting height adjustment

Deck height is adjustable from 1.5"- 5.5" in. Simply push the display deck height button on the left control panel up or down in ¼" increments to adjust level of mowing. Pressing and holding the up or down arrows will scroll the numbers for faster adjustment. Once the button is released, the deck will move to selected height. Deck height display (on left side of control panel) shows number in inches at which the operator is mowing. Deck can also be raised quickly while mowing is in progress to avoid stumps, rocks or another obstacle that can damage mower deck by using foot pedal on front foot rest. When lowering deck with foot pedal, deck will not go below previously selected height.

Setting Minimum Deck Height

The administrator is capable of setting a minimum deck height if desired. This restricts the deck from going below the set height. To adjust, select the mower application page, press the settings icon and enter your administrator passcode. Set the minimum deck height and return to home screen after set.

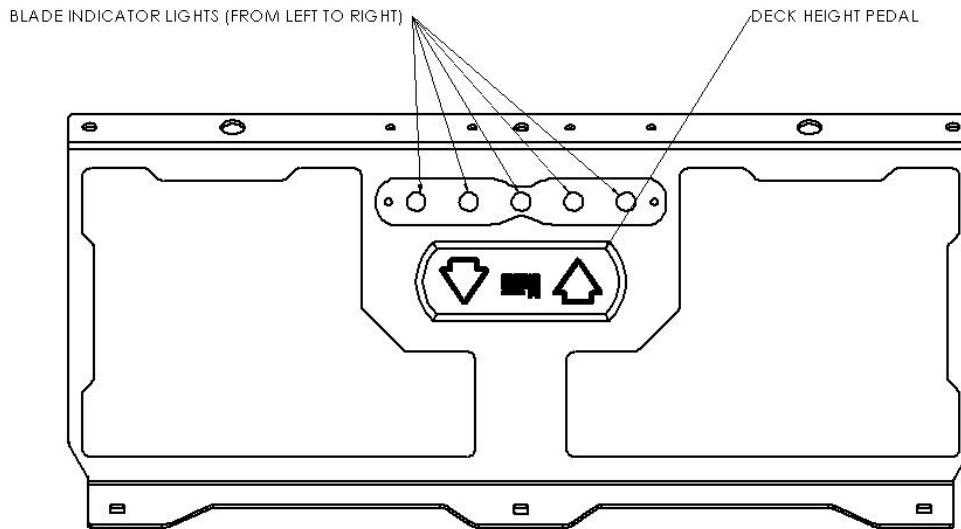

Fig. 5C



On touch screen display, control height of deck and set to desired height on display screen.

Anti-scalp wheels

Anti-scalp wheel kits are standard on Mean Green Mower units. These anti-scalp wheels are designed to minimize scalping when mowing on rough uneven terrain. After setting the cutting height, adjust the anti-scalp wheels so they extend below the deck but **do not contact the ground**. They should always be at least 1/4" to 3/4" below the deck. With the unit sitting on a flat level surface, the wheel position can be adjusted up or down as needed from 3/4" to 1-3/4" below the blade surface. Move the wheels up or down, in 1/2" increments, using the different axle mount holes in the wheel mount bracket.

Manual Brake Release Hubs (pg. 32-33)

If towing or manual pushing is needed:

Located on the center hub of each rear wheel.

1. Use a 7/16" to unscrew 2 ea. 3/4" bolts.
2. Take the washer off and turn around so the extrusion pushes inward.
3. Screw 2 ea. bolts back in and the brakes will now be disengaged

NOTE: Never drive mower with brakes released. Always have drives in engaged position before driving! Failure to re-engage drive brakes could cause serious damage to your mower and void mower warranty!!!!

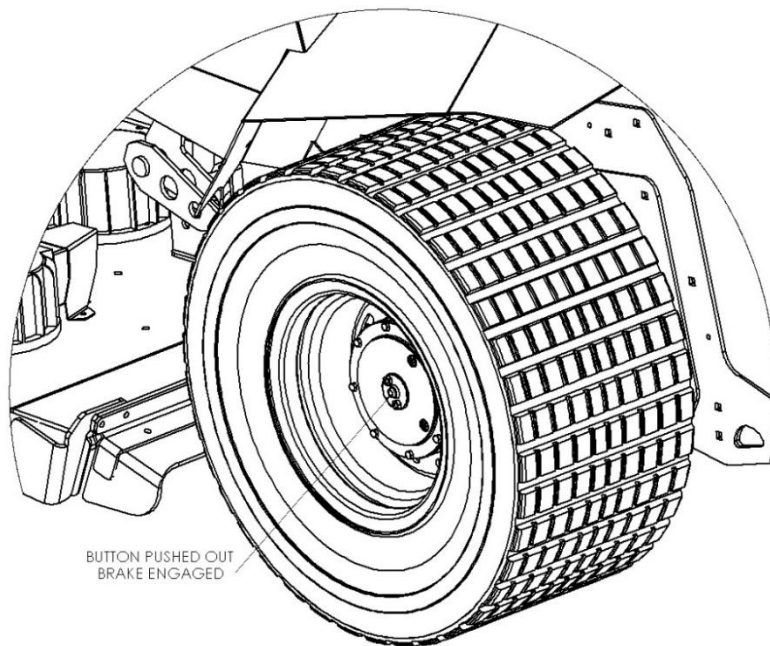

Fig. 6A

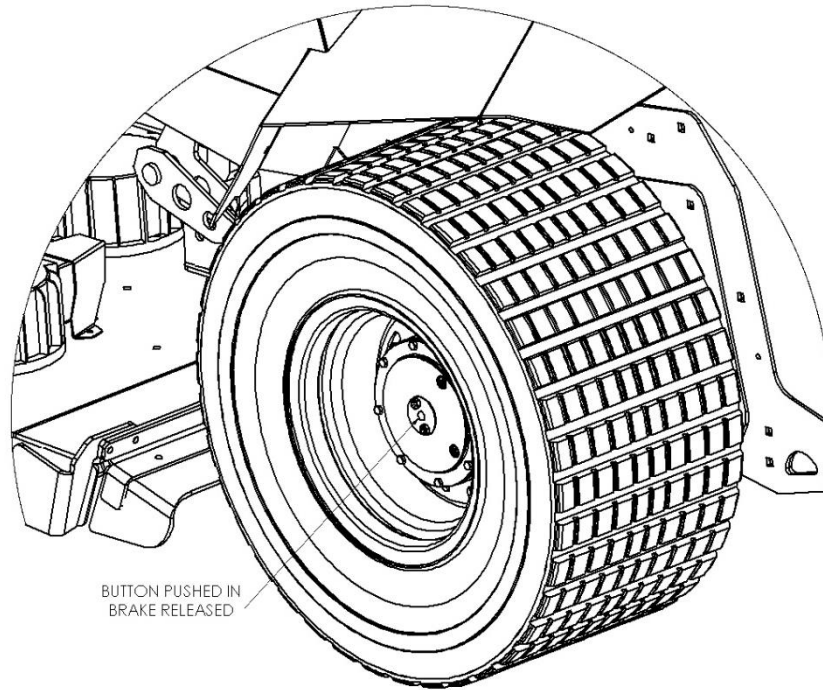

Fig.6B

MAINTENANCE & ADJUSTMENTS

Safe Servicing Practices

This product is capable of amputating hands and feet and throwing objects. Always follow all safety instructions to avoid serious injury or death.

NOTE: Always turn mower OFF and turn battery disconnect switch to OFF when any maintenance or repairs are performed on mower unit!

Service

Park the mower on level ground. Make sure that steering control levers are in the neutral position, deck blade switch in OFF position, raise deck, turn mower to OFF position, and turn battery disconnect switch to OFF.

IMPORTANT! Wait for all movement to stop before adjusting, cleaning or repairing. Repairs or maintenance requiring power should be performed by trained maintenance personnel only. Read and observe safety warnings in front of manual. **Any maintenance operation that requires the removal of safety covers must be performed by a trained service technician.**

Before working on or under the deck, make certain to press the push button to OFF and deck blade switch cannot be accidentally started and turn the battery disconnect to OFF by turning switch on back of mower on the battery compartment.

IMPORTANT! Repairs or maintenance requiring power should be performed by trained maintenance personnel only. Use a stick or similar instrument to clean under the mower making sure that no part of the body, especially arms and hands are under mower. Keep your machine clean and remove any deposits of trash and clippings, which can cause fires and overheating. Allow machine to cool before storing. **Clean flammable material from machine. Prevent fires by keeping battery compartment, deck and operator's station clean of accumulated trash, grass clippings, and other debris.**

Clean battery compartment, drive motor compartment, mower deck, seat etc. of all dirt and debris. **DO NOT** spray battery/electronics compartment with water. Clean area with compressed air or blower only. Do not use, solvents, hard cleaners or abrasives. Wash exterior mower with mild soap and water. Always wear adequate eye protection when servicing the batteries, or when grinding mower blades and removing accumulated debris. Never attempt to make any adjustments or repairs to the mower's drive system, mower deck or any attachment while the traction drive system is running. Repairs or maintenance requiring power should be performed by trained maintenance personnel only. Never work under the machine or attachment unless it is safely supported with jack stands. Make certain machine is secure when it is raised and placed on the jack stands. The jack stands should not allow the machine to move when the traction drive system is running and the drive wheels are rotating. **Use only certified jack stands.** Use only appropriate jack stands, with a minimum weight rating of 2000 pounds (907.2 kg) to block the unit up. Use in pairs only. Follow the instructions supplied with the vehicle stands. Do not touch hot parts of machine. See Fig. 6C for rear jack and jack stand locations.

Keep nuts and bolts tight, especially the blade attachment bolts. Keep equipment in good working condition. Never tamper with safety devices. Check their proper operation regularly. Turn the key to the OFF position before unclogging the discharge chute. Never clear the discharge chute with the machine running. Turn the key to the OFF position and be sure the blades have stopped before cleaning. Use a stick to clear a plugged discharge area. **DO NOT use your hand!** Stop unit, and allow blades to stop before unclogging chute. Grass collection system components are subject to wear, damage and deterioration, which could expose moving parts or allow objects to be thrown. Frequently check components and replace with manufacturer's recommended parts, when necessary. Exercise caution when working under the deck as the mower blades are extremely sharp. Wear gloves and use extra caution when servicing them. Use only genuine Mean Green Mower parts to ensure that original standards are maintained.

NOTE: Always turn mower OFF and turn battery disconnect switch OFF when any maintenance or repairs are performed on mower unit! Always disconnect batteries when transporting unit. Keep unit free of grass clippings, leaves and other debris.

DO NOT spray battery/electronics compartment with water to clean unit. Use only compressed air or blower. Wear adequate eye and hearing protection when cleaning the unit. Always wear safety glasses and protective gear near batteries. Use insulated tools.

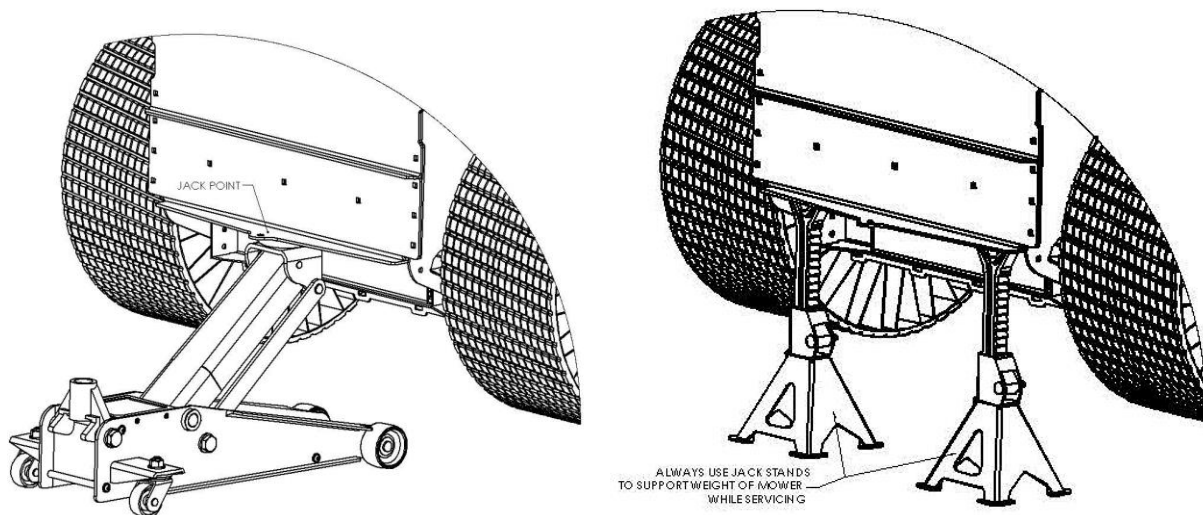

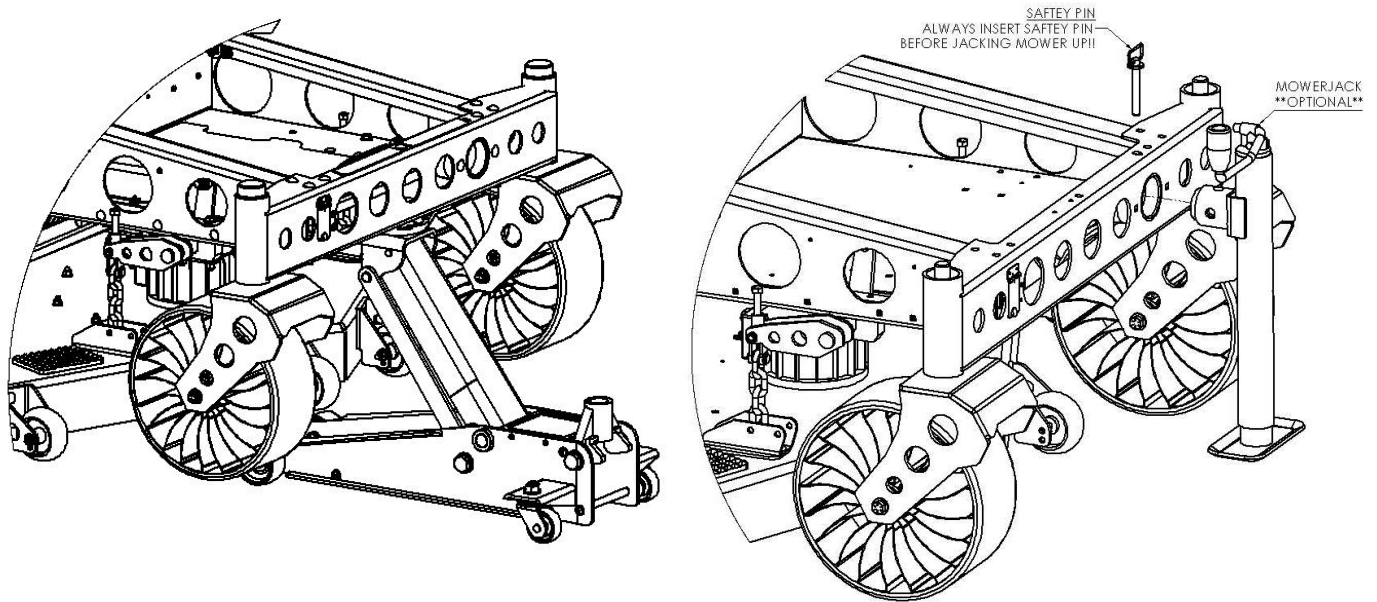

Fig. 6C

Regular Maintenance

Regular maintenance is the best prevention for costly downtime or expensive, premature repair. The following pages contain suggested maintenance information and schedules which the operator should follow on a routine basis. For more detailed information order the correct parts manual for your unit. Remain alert for unusual noises, they could be signaling a problem. Visually inspect the machine for any abnormal wear or damage. A good time to detect potential problems is while performing scheduled maintenance service. Correcting the problem as quickly as possible is the best insurance.

Daily inspect mower for grass clippings and wire and string tangles. The underside of the mower deck may collect a buildup of grass clippings and dirt, especially when grass is wet or has high moisture content. This build-up will harden, restricting blade and air movement and will probably show a poorer quality of cutting. Therefore, it should be removed routinely. To do this it will be necessary to raise and block the deck, using jack stands or blocks, in the full up position and scrape the build-up from underneath. Some repairs require the assistance of a trained service mechanic and should not be attempted by unskilled personnel. Consult Mean Green Products when assistance is needed.

⚠ Torque Values: WARNING: Particular attention must be given to tightening the drive wheel lug nuts and blade spindle bolts. Failure to correctly torque these items may result in the loss of a wheel or blade, which can cause serious damage or personal injury. Call your Mean Green Products Dealer for assistance.

Torque values are given below:

Ft.-lbs.

Wheel (lug) Nuts.....65-75

Blade spindle bolt bottom...30 Ft.-lbs. (**BLACK** Motors) OR 60 Ft.-lbs. (**SILVER** Motors)

Lug nuts only - It is recommended that these be checked after the first 2 hours of operation, initially, every 100 hours and following removal for repair or replacement.

Tires

It is important for level mowing that the rear tires have the same amount of air pressure. The recommended pressures are: 12 psi in rear tires. Front tires are either no flat tires (do not require air) OR Michelin Caster Tweels (do not require air)

Lubrication

Use SAE multi-purpose grease for front wheel bearings for no flat tires. **IMPORTANT:** Recommended maintenance at the beginning of each mowing season AND every 50 hours of operation.

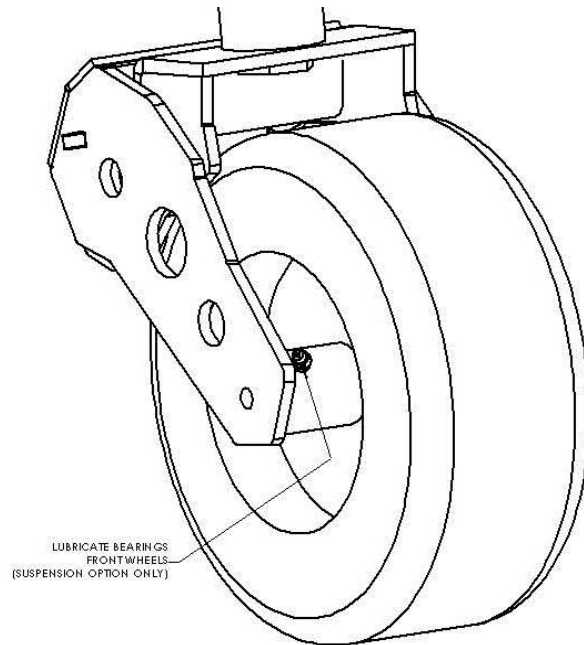

Fig.5A

Electrical system

This mower operates on a 48-volt electrical system. Refer to the *Electrical* section of this manual for detailed information. Electrical System Located Under Operator Seat – **SEE SEAT RELEASE LATCH** or instructions on how to access electrical compartment!

Seat adjustment

The seat can be adjusted forward and rearward by moving the black seat lever (bottom right seat fig.5B) to the right side.

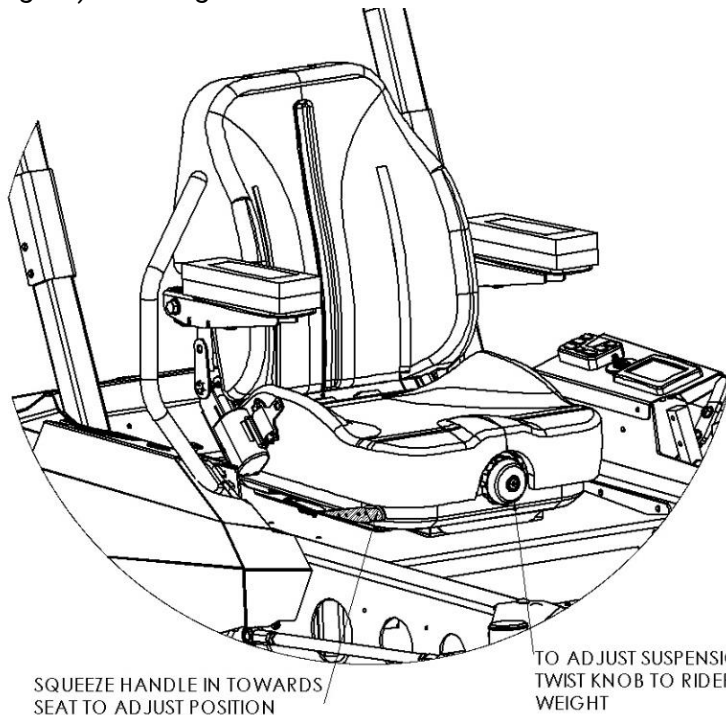

IMPORTANT! *Make sure that the seat locks into place after changing positions! *
IMPORTANT! Adjust seat to where operator has best comfort and control.

5B

Seat Release Latch (Fig.5E) (located left & right side of mower behind seat)

1. Slide seat forward. 2. Push forward on seat latch and lift up on rear of seat. **IMPORTANT: NEVER expose electrical system to water when seat is in the UP position!**

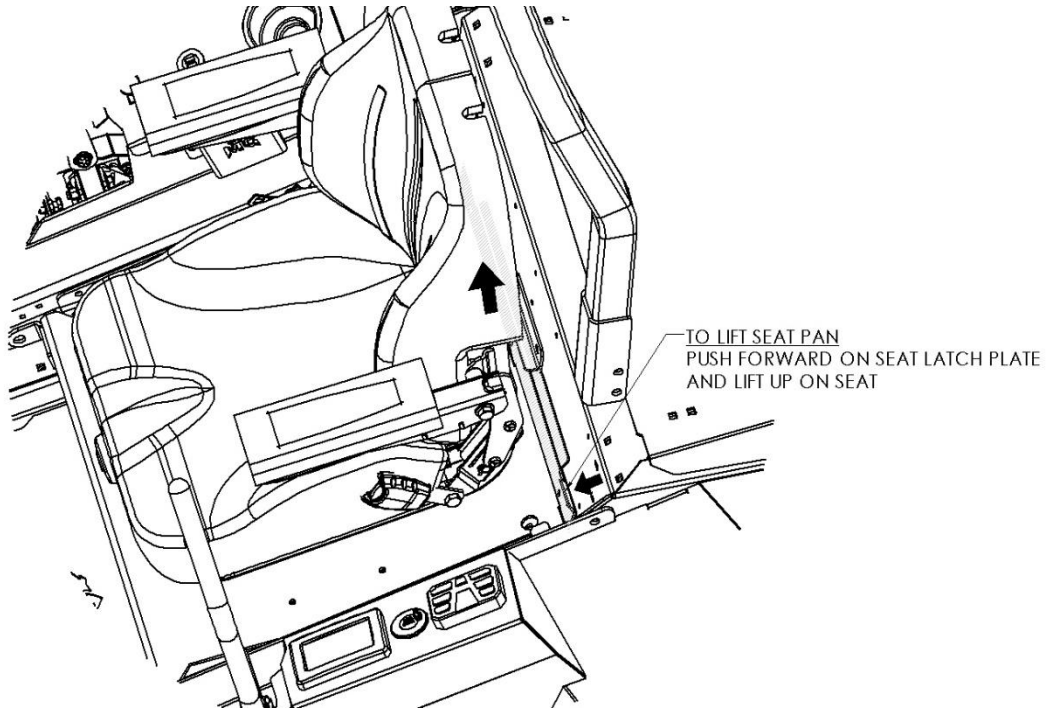

5E

FILTER CLEANING MAINTENANCE SUPPLEMENT CXR-52 & CXR-60 Models

****To Be Performed Every 20 hrs. Or Less If Needed Depending On Conditions****

1. Turn Mower OFF
2. Clean Filter With Compressed Air. *****NOTE: Never Operate Mower Without Filter In Place!!! Damage Could Occur to Mower Unit.**

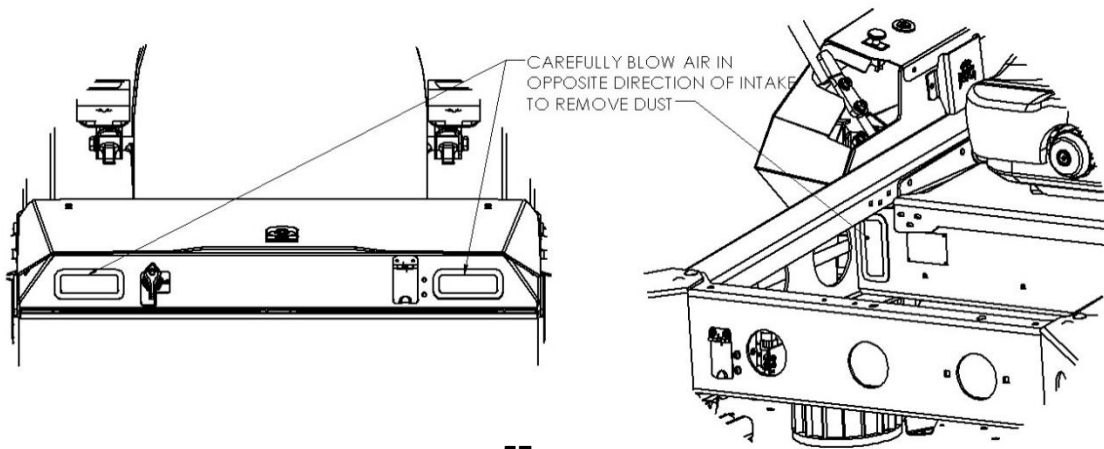

5F

Battery Compartment OPEN/CLOSE Handle and Battery Lock (Fig.6G)

Depress button and LIFT UP on battery compartment cover to access Lithium Energy Modules (LEMs). PUSH DOWN on cover and depress latch until it clicks to secure battery compartment cover when operating mower. Battery Cover handle can be locked with the use of a key lock near the push button release.

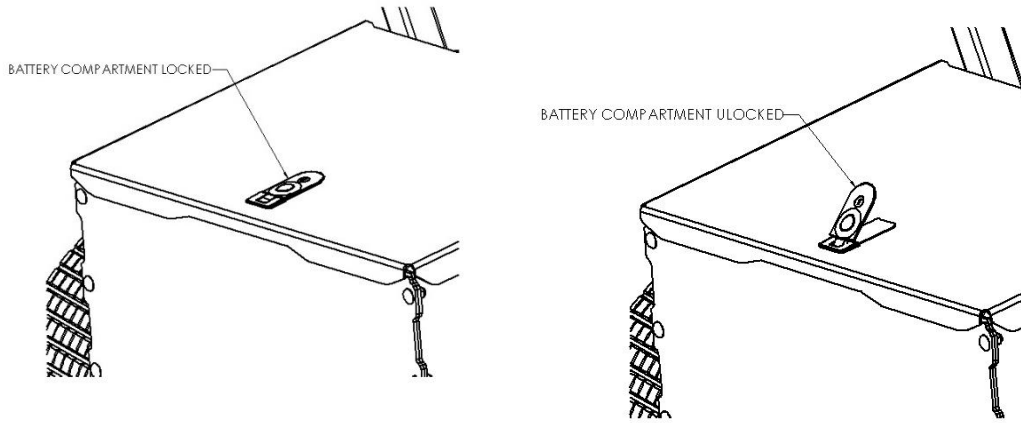





Fig. 6G

Mower blade maintenance

Check the mower blades daily, they are the key to power efficiency and well-groomed turf. Keep them sharp, a dull blade will tear rather than cut the grass, leaving a brown ragged top on the grass within a few hours. A dull blade also requires more power. Replace any blade which is bent, cracked or broken.

 **WARNING:** Never attempt to straighten a bent blade by heating, or weld a cracked or broken blade as the blade may break and cause serious injury. Replace worn or damaged blades.

 **DANGER:** Never work with blades while mower push button is ON. Turn mower OFF and disconnect battery cables by turning the battery disconnect switch to OFF position! Block up mower when you must work under it. Wear gloves when handling blades. Always check for blade damage if mower strikes a rock, branch or other foreign objects during mowing!

 **WARNING:** Always wear adequate eye protection when grinding mower blades.

Mower blade removal (Refer to Fig.20A-F)

MGUPN066: The torque values for the nut that holds in the blade.

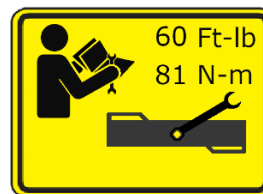

Refer to your approved ZTR Jack instructions to raise the front of mower. Use a 3/4" wrench or socket to remove the 1/2" hex head bolt holding the blade to the motor shaft from underneath. It may be necessary to use a 1-1/4" channel lock pliers to keep the blade adapter from turning while removing blade bolt.

NOTE: The blade adapter will come off when the blade bolt is removed. Touch-up sharpening can be done with a file. Check the blades for balance following grinding. A commercial balancing tool is available through most hardware supply stores, or balancing can be done by placing the blade on an inverted line punch or 1/2" bolt. Blade should not lean or tilt. Spin the blade slowly, blade should not wobble. If blade is

out of balance, true it up before reinstalling. Lay the blade on a flat surface and check for distortion. Replace any distorted blade.

Mower blade installation (Refer to Fig.20A-F)

Do not re-use spindle bolts which have stripped, worn or undercut threads. Make sure that the blade adapter is seated properly on the blade motor shaft before tightening the blade cap screw. Use a 3/4" socket with a torque wrench to re-attach the blade to the motor shaft from underneath. It will be necessary to use a 1-1/4" channel lock pliers to keep the blade adapter from turning. Torque cap screws on motor shafts to 60 foot-pounds for **SILVER** motors when reinstalling blades. **IMPORTANT:** The blade sail (curved part) must be pointing upward toward the inside of the deck to ensure proper cutting. Rear discharge mulching decks may require a special "LH" blade on the right side of the deck. Be sure to replace blades in proper location.

IMPORTANT: When mounting blades, rotate them after installation to ensure blade tips do not touch each other or sides of the mower.

 **WARNING:** Failure to correctly torque the bolt may result in the loss of the blade which can cause serious injury.

 **WARNING:** Mower blades are sharp and can cut. Wear gloves and use extra caution when servicing them.

See Figure 20A & B for instructions to turn off the power and to disconnect the battery BEFORE attempting to jack or service mower. See below figures 20C, 20D, and 20E for typical jacking and jack stand positioning.

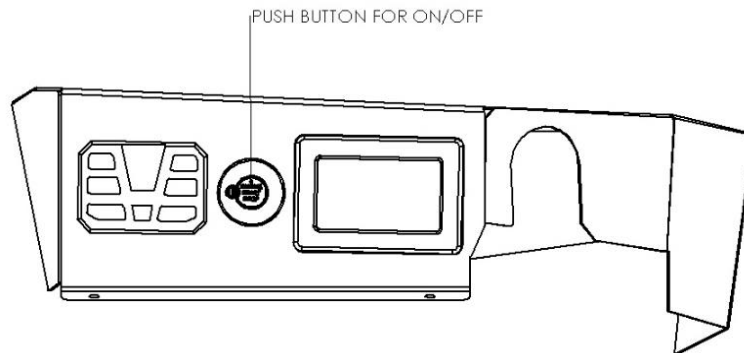

Fig.20A

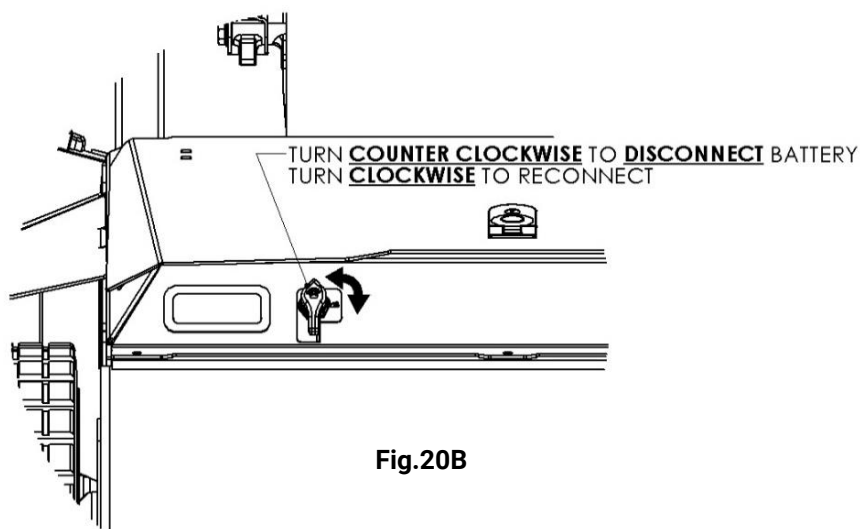

Fig.20B

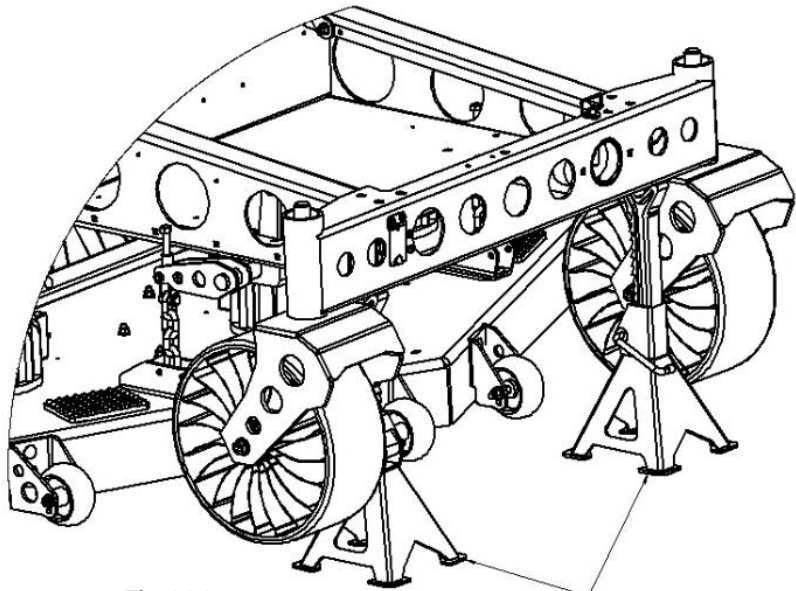

Fig.20C

ALWAYS USE JACK STANDS
TO SUPPORT WEIGH
WHILE SERVICING

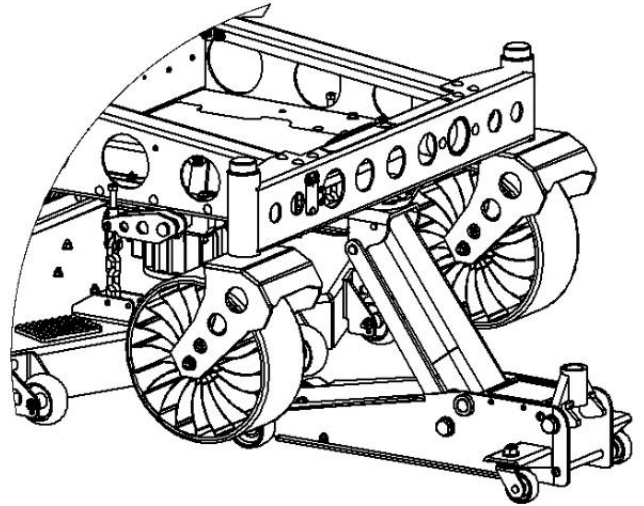
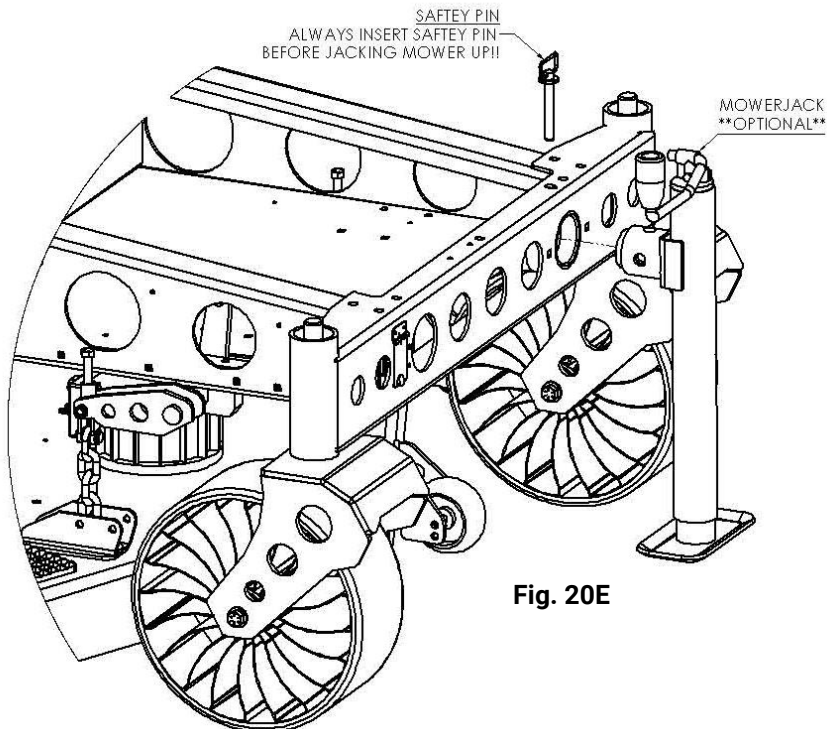

Fig.20D



SAFETY PIN
ALWAYS INSERT SAFETY PIN
BEFORE JACKING MOWER UP!!

MOWERJACK
OPTIONAL

Fig. 20E

See Figure 20F for a typical deck configuration and proper blade placement and rotation.

Fig.20F

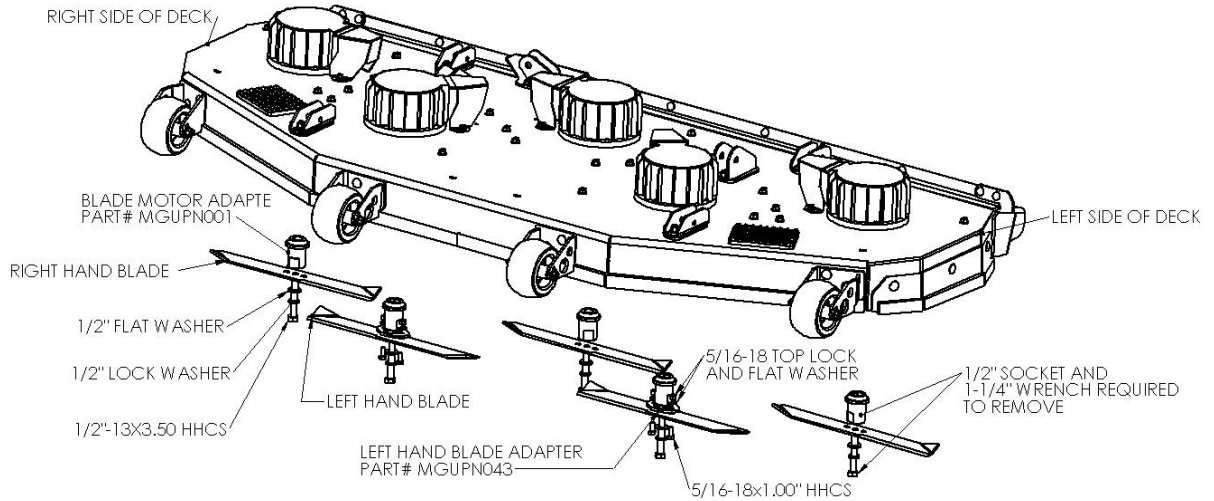

NOTE: Front two blades rotate counter clockwise when mulching baffles are installed and when no mulching baffles are installed! (Fig. 20G)

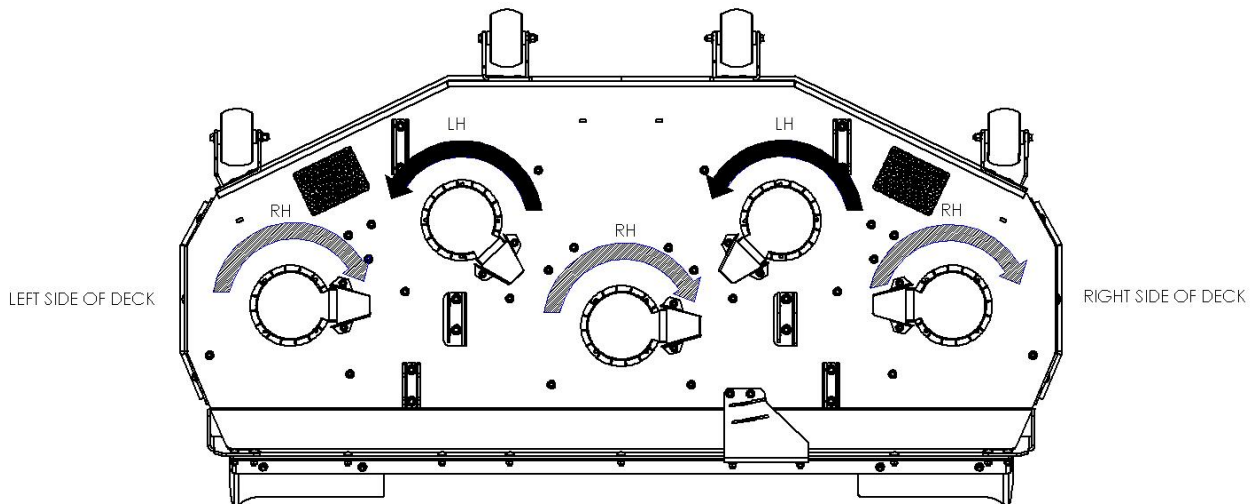
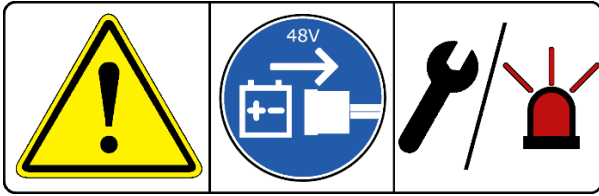

Fig. 20G

ELECTRICAL SYSTEM

Electrical System Safety



MGUPN072: Disconnect the battery before maintenance or in an emergency. If the steps are not performed, there is a chance for injury.

Turn mower to OFF position by pressing the push button, disconnect battery cables by turning the battery disconnect switch to OFF and read owner's manual before adjusting or repairing unit. Keep unit free of grass clippings, leaves and other debris. **DO NOT spray water in electrical compartment to clean unit. Use only compressed air or blower.** Wear adequate eye protection when cleaning the unit. Always wear safety glasses and protective gear near batteries. Use insulated tools. Clean battery compartment, drive motor compartment, mower deck, seat etc. of all dirt and debris. **Do not spray battery/electronics compartment with water. Use only compressed air or blower.** Avoid injury. Press the push button start, enter passcode and mower blade will engage when deck switch is engaged, even if drive motor is not turning. Keep area clear of bystanders when engaging blade switch. All maintenance and storage areas should be properly ventilated in accordance with applicable fire codes and ordinances to avoid fire hazards. Never allow flames, sparks or smoking near batteries. Keep batteries out of reach of children. Always keep protective shields, covers and guards in place and securely fastened. If they become damaged, repair or replace immediately. **Never modify or remove safety devices.**

Electrical System Information

The Mean Green Mower is powered by a 48-volt electrical system. It consists of the following components:

1. Deck controllers (5)
2. Deck Motors (5)
3. Drive Controller - right (1)
4. Drive Controller - left (1)
5. Touch Screen Display (1)
6. Impulse Drive System™ Hub Drives (2)
7. Lithium Energy Modules (LEMs) (1)

Component Maintenance

IMPORTANT: Maintenance for the various electrical components found on the Mean Green Mower should only be performed by a Mean Green Products trained technician.

IMPORTANT: When battery voltage becomes low, drive motors will slow to “creep” mode (2mph). When the batteries discharge to this point, they require recharging. **The mower blades should be disengaged and the unit should immediately be returned to the battery charging area. Then connect unit to the battery charger.**



WARNING: Do not attempt to cross roads or railways with low battery levels.

Battery Safety



WARNING: Unplug charger from power outlet before connecting or disconnecting from the mower charger port. Always wear safety glasses and protective clothing/gear. Use insulated tools. Prevent the battery terminals from touching any metal mower parts when removing or installing battery. Do not allow

metal tools to short between the battery terminals and metal mower parts. Always keep protective battery covers in place.

 **WARNING:** Incorrect battery cable routing could cause damage to the mower and battery cables. This can cause sparks which can cause a battery short circuit which could result in serious personal injury.

 **WARNING:** Always disconnect battery cables by turning the battery disconnect switch to OFF position when transporting unit.

Battery Connectors

Always disconnect battery cables by turning the battery disconnect switch to OFF position before performing maintenance on the unit.

Battery Maintenance

Your Mean Green Mower is powered by 1 Lithium Module (LEM) which, when maintained properly, will provide years of useful life. **For proper care, adhere to the instructions on page 47.**

 **WARNING:** Charge only with a Mean Green Mower approved charger. Do not use battery chargers other than those recommended by Mean Green Products. Incorrect battery charging will void warranty and can lead to equipment damage, fire, serious injury or death.

1. Always charge batteries after each use, regardless of how little used. Once charging is complete, charger can be disconnected. Charger may not turn back on once charging is complete. **NOTE: Unplug charger from outlet and then from mower charging port!**
2. Check that battery cables are securely tightened to batteries each time you service the battery.
3. Keep grass, dirt and debris from collecting near battery terminals.
4. Batteries are not to remain in a discharged state or damage to the batteries will occur. Immediately charge at least 15 minutes after a complete discharge of battery pack.
5. Charge batteries indoors in a well-ventilated and dry location away from sparks or flames. Never expose charger to rain, vapor or liquid (dry location use only).
6. **Charge only** Lithium Modules (LEMs) provided with the Mean Green Mower.
7. Do not touch un-insulated portion of charger (terminal pins) of output connector. (if applicable on model)
8. Do not use with defective cords and wires. Replace defective cords and wires immediately.

Battery Charging Procedures and Options

 **WARNING: Batteries should not be removed from unit unless repair is needed. Use EXTREME Caution When Lifting Batteries Out Of Mower Unit. Serious Injury to operator and/or Battery Could Occur If Battery Is Mishandled or Dropped!!**

 **WARNING: Do Not Use An Extension Cord To Charge Mower!** If an extension cord must be used, it must have a minimum of 10 AWG wires and be of the shortest length possible (10-25 ft long). Never leave any cords coiled as excessive heat can build up and melt insulation of extension cord wires!

Chargers include: LEMC6048 (Standard Charger)

See separate guidelines for each below!

The charger will charge from a Standard 220-240V outlet at 60 amps-48volts. This will be drawing around 13 amps from the wall outlet. **NOTE: It is recommended to have a dedicated circuit for charging!!**

 **DO NOT USE extension cords with chargers (see above note)!!**

Pictured below notice the charger has a fan on the top of unit for cooling and 2 cords – 1 from the left side and 1 from the right side. The cord with the RED Anderson Connector plugs into the charging port of the mower and the second cord plugs into the electrical wall outlet. The charger also has a light on the front of the unit – RED indicates charging and GREEN indicates battery is charged.

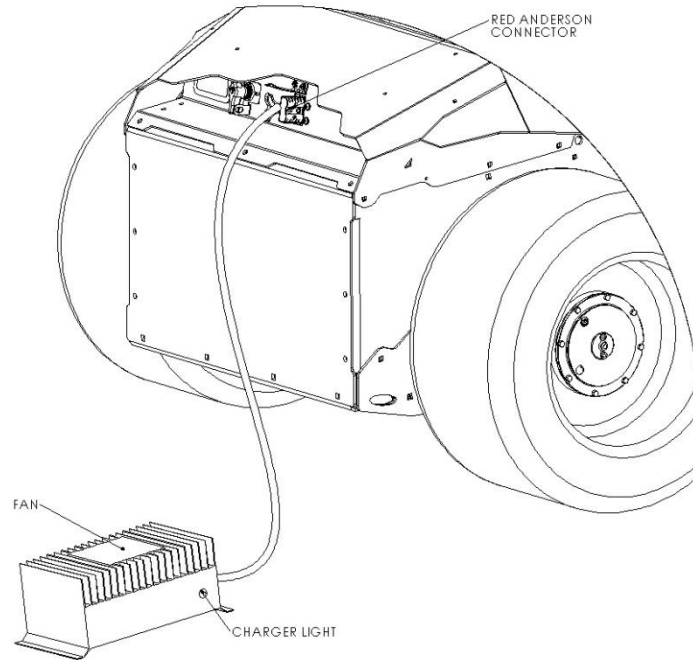

Fig. S1

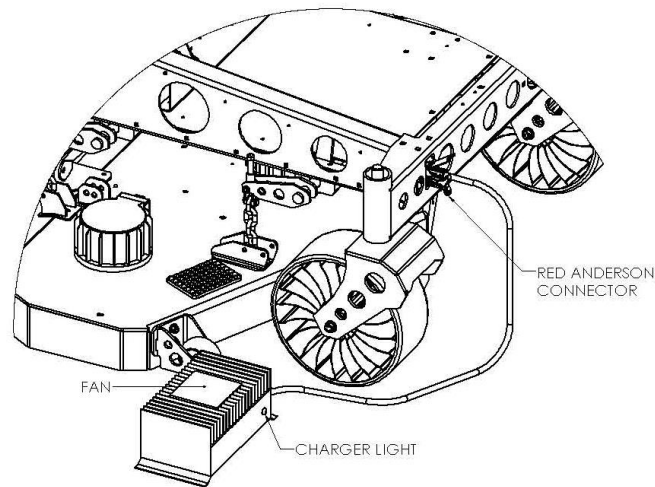

Fig.S2

Charging Recommendations:

**** See page 48 Lithium Energy Module Maintenance and Care****

Proper Connection and Disconnection of Charger Units:

- 1) Connect the charger to the mower charging port with the Red Anderson Connector in front or rear. (Fig.S1or S2) Note: Mower will not drive when charger is plugged into any charge port. Press the push button start. (No need to enter passcode) Plug charger into 120VAC-240VAC wall outlet. You will see a red light on the charger unit and cooling fan will turn on. This will indicate the charger is functioning properly.

- 2) A fault code “No Charger Power Detected” will come up on display screen until the charger is turned on. (Fig. S3 & S4) (If state of charge is over 95% fault code will not display) Fault code goes away once charger is plugged in and screen displays charging current, amps and display battery pack voltage. Display will automatically turn off after 15 minutes, but charger will continue to charge. To wake display while charging to see current state of charge, press the push button start and display will come back on or push again to turn display off.

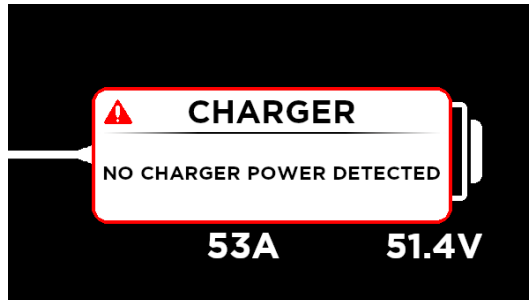

Fig. S3

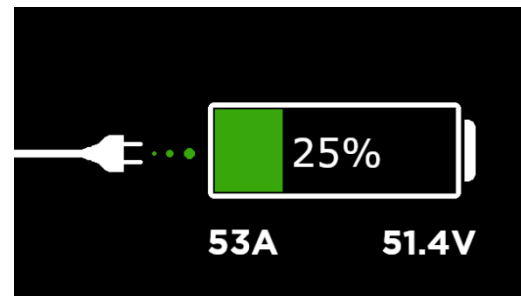

Fig. S4

- 3) When unit is fully charged, the light on the charger will turn GREEN and cooling fan will turn off. To disconnect the charger, unplug charger from outlet FIRST then proceed to unplug the charger from mower charging port. IMPORTANT: IF YOU DO NOT UNPLUG CHARGER FROM WALL OUTLET FIRST, the GREEN light may stay on and the charger may not reset for the next charge. If this occurs, unplug the charger from the wall outlet and wait until the GREEN light turns off (NOTE: this may take up to 40 seconds). NOTE – If you have purchased a charger with a manufacture date of January 2019 or later, the charger will reset without having to unplug the unit from the wall outlet.
- 4) After charging is complete, the red charger connector can be removed from mower. If connector is not disconnected from the mower then the safety arm on the charger connector will not allow the mower to drive and a fault code will appear on display. Simply remove the connector from the mower and the fault will be corrected and drives will function as normal. Refer to Figure S5.

***Always refer to the Charger Manual for more information about the proper operation of the charger or call Mean Green Customer Service at: 513-738-4736

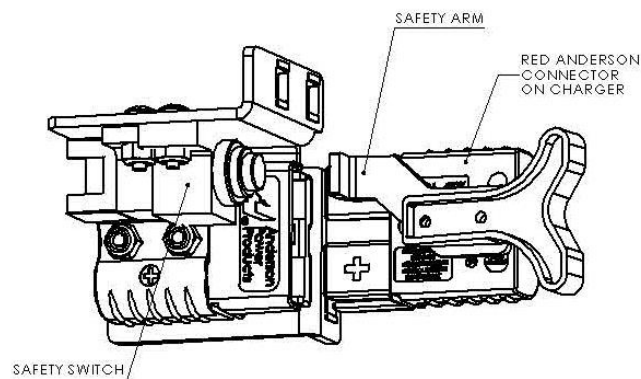

Fig. S3

 **WARNING: Do not smoke** while servicing the batteries.

Disconnecting the Batteries (LITHIUM MODULES)

NOTE: ALWAYS disconnect battery cables by turning the battery disconnect switch to OFF position before **ANY** maintenance is performed on mower unit. The battery disconnect switch is located on the back of the mower on the left side. Turn red switch to OFF and batteries will disconnect.

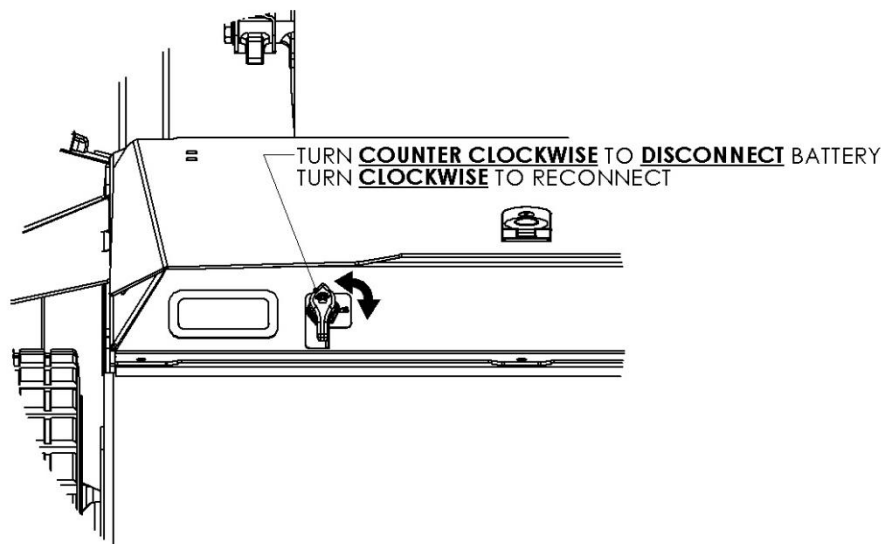

Fig. F

Battery Storage

See page 47 Lithium Energy Module Maintenance & Care

TROUBLESHOOTING SYMPTOMS & PROBABLE CAUSES SUGGESTED REMEDIES

FOR ANY ELECTRICAL PROBLEMS

****RESET Mower Electronics by Switching mower to OFF position with push button for approximately 5 seconds & then back to ON position. ****

Mower blades stop while mowing

When battery voltage becomes low, drive motors will slow to "creep" mode (2mph). When the batteries discharge to this point, they require recharging. **The mower blades should be disengaged and the unit should immediately be returned to the battery charging area. Then connect unit to the battery charger.**

Uneven cutting height

The blade(s) are not sharp. Sharpen the blades. A cutting blade(s) is/are bent. Install new cutting blade(s). The deck is not level - Contact your Mean Green Products Dealer. The underside of the deck is dirty. Clean the underside of the deck. Tires improperly inflated. Adjust air pressure to proper psi. A blade spindle is bent. Contact your Mean Green Products Dealer.

Loss of deck operation

The deck fails to operate with fully charged batteries.

RESET Mower Electronics by turning mower to OFF position with push button for approximately 5 seconds & then back to ON position. If this does not remedy the problem - Contact your Mean Green Products Dealer.

Mower will not start

Check that push button start is pressed ON.

Check all battery connections by making sure red battery disconnect switch is turned ON.

Make sure batteries are charged.

Mower drives stop due to low charge & mower will not move or moves in “creep” mode

Turn blades off, turn mower OFF, wait approximately 5 seconds and then back to ON (this resets computer)

If manual operation is needed to return to charging station or to move mower without battery power, both Manual Brake Release Hubs to release drive brakes and push or tow mower **slowly**.

NOTE: Never drive mower with manual brakes released. Always re-engage manual brake releases before driving! Failure to re-engage drive levers could cause serious damage to your mower and void mower warranty!!!!

STORAGE

When storing the unit at the end of the mowing season, the following steps should be taken to ensure readiness for the next mowing season.

1. Remove all grass, dirt, and trash from mower.

IMPORTANT: Wash the outer machine with a mild detergent and water. **Do not wash the electronics/battery compartment of the mower!**

Avoid excessive use of water near the control switches on panel.

DO NOT get water in electrical compartment or in battery compartment!!!

IMPORTANT: Excessive water use may void warranty if guidelines are not followed!

2. Check thoroughly for any worn or damaged parts that need replacing and order them from your dealer.

3. Thoroughly lubricate wheel bearings, according to lubrication instructions. IF APPLICABLE.

4. Charge batteries to 50-60%.

5. Do not deflate tires.

6. The mower should be stored in a well ventilated, clean and dry place as the battery charger cannot be used in a wet environment.

7. Do not operate mower if battery temperature is below 0 degrees Fahrenheit. Do not charge batteries if below 32 degrees Fahrenheit.

****See below for Lithium Energy Module Maintenance & Care****

New season preparation

Before starting the mower following post season storage, the following servicing is required:

1. Clean machine, removing trash and dirt accumulation.

2. Review safety precautions listed in this manual.

3. Check and inflate rear tires to recommended pressure of 12 psi. If No Flat tires on front, no air required.

4. Make sure that batteries are fully charged.

5. Grease wheel bearings (SAE multi-purpose grease) IF APPLICABLE.

Lithium Energy Module Maintenance and Care



IMPORTANT:

In order to prolong the battery module cycle life and make sure the module stays in good condition, please read the following instructions:

1. Whenever a battery pack is fully discharged and automatically turned off, DO NOT USE IT AGAIN until it is recharged. Over discharge of the battery pack means the battery life will be shortened and the battery may become permanently damaged.
2. Whenever a battery pack is fully discharged and turned off, it is best to recharge the battery as soon as possible, there is no need to fully charge, it will even be beneficial if you only charge the module for 5-10 minutes. It is best to recharge it within 24 hours.
3. For charging, charge all modules while connected together.
4. Before connecting modules together in parallel, please make sure the modules have the SAME SOC (state of charge or voltage). Different SOC means different voltage and may charge & discharge to each other rapidly, which is not ideal for the modules.
5. If the battery will not be used for a long time (several weeks), please disconnect battery from the machine by turning the battery disconnect switch to OFF position.
6. Storage for long periods is okay even below -23C (-10F). Best to have SOC at about 30-70% or minor cycle life reduction is possible.
7. For long term storage, it is best to cycle (charge and discharge) battery every 3-9 months when above freezing.
8. NEVER CHARGE the battery below 0 Celsius. Charging is much, much more detrimental in cold weather than discharging. We have our newer BMSs set to not allow charging below 0C.
9. Discharging is okay down to -23C (-10F) and even lower, but the capacity/runtime is drastically reduced overall as it gets colder. Life cycle may be reduced, but minor amounts if just occasional use below 0F.
10. Avoid severe vibration. Do not throw or drop the battery pack.

ROPS (Roll Over Protection System)





1. When the roll bar is in the down position, do not buckle up when operating the mower.
2. When the roll bar is up, keep the seatbelt fastened.
3. When moving fast, do not make sharp turns.
4. Make sharp turns only when moving slow.

MGUPN076

To Fold the ROPS:

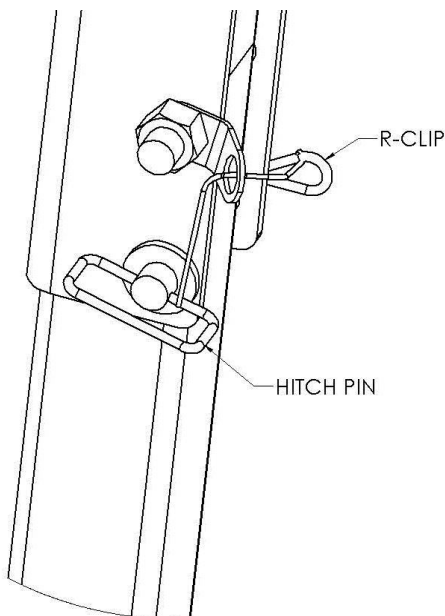
1. Remove both R-Clips and then pull outward on Hitch Pins.
2. Fold the ROPS slowly rearward.
3. Reinstall Hitch Pins and R-Clips into holes in ROPS frame to lock.



 **To avoid personal injury: Make sure that both Hitch Pins are properly installed and secured with R-Clips.**

To Raise the ROPS to Upright Position

1. Remove both R-Clips and Hitch Pins.
2. Raise ROPS to the upright position.
3. Align Hitch Pin holes, insert both pins and secure with R-Clips.

Fig. J



MEANGREEN

M O W E R S

Mean Green Mowers
4404 Hamilton Cleves Rd. Ste. 2
Hamilton, OH 45013
513-738-GREN (4736)
Email: sales@meangreenproducts.com
www.meangreenproducts.com

THE FUTURE IS GREEN