

# ***OVERSEEDER 1430A***

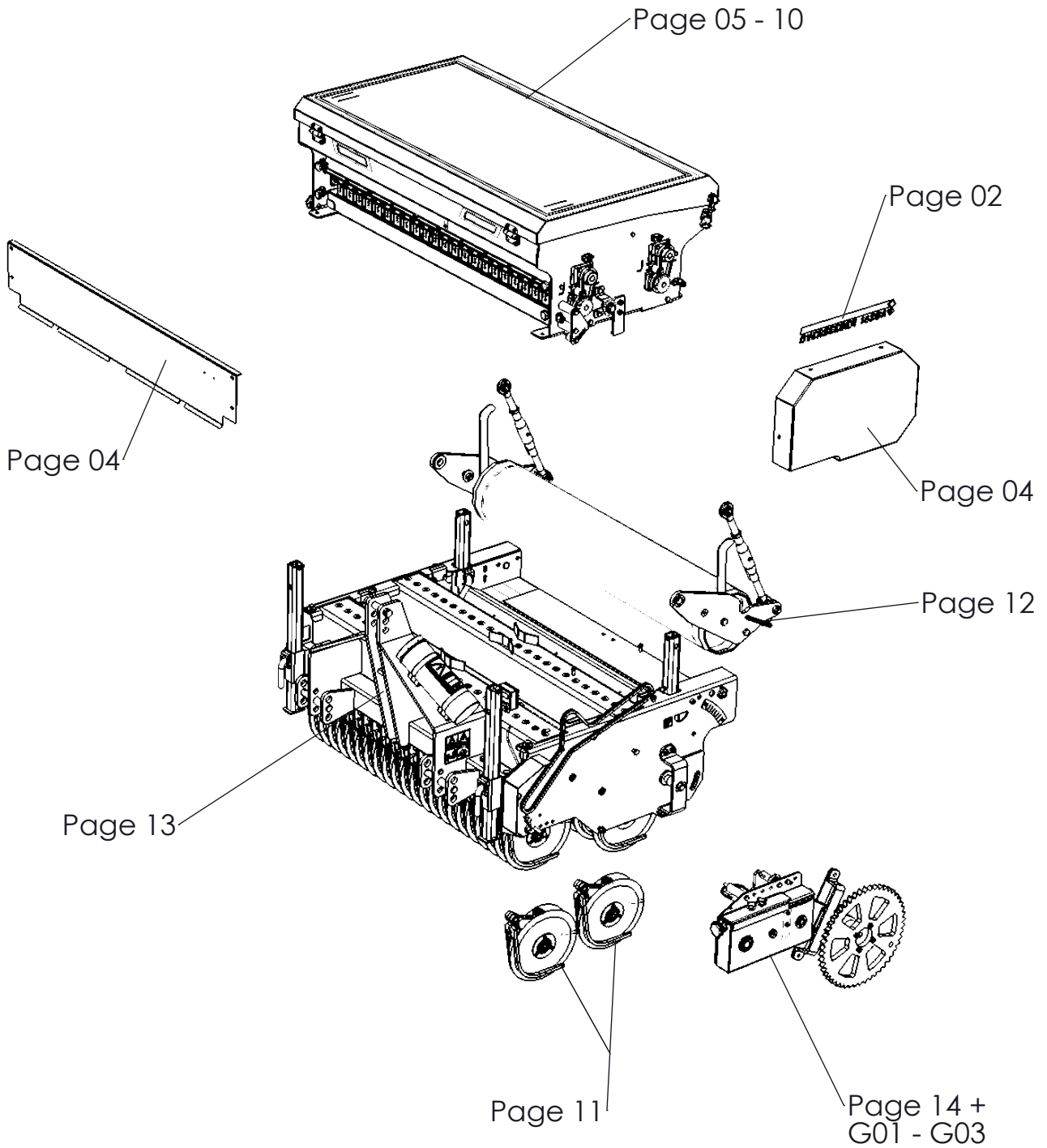

Version: 2142





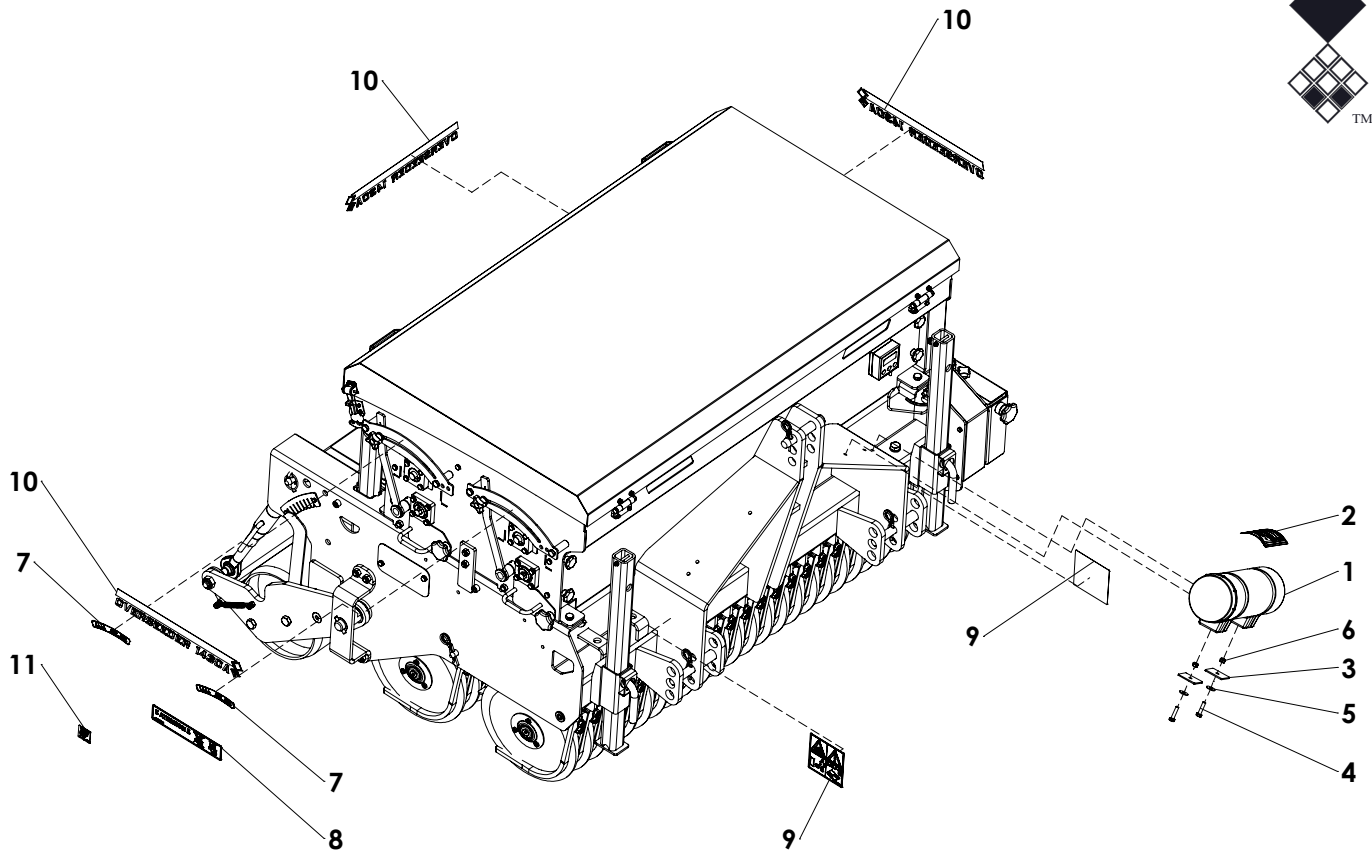

ITEM	PART NUMBER	DESCRIPTION	REMARKS	QUA
1	444.803.100	Toolbox Complete		1
2	900.280.402	Safety decall manual		1
3	468.030.530	Toolbox contraplate		2
4	804.080.350	Bolt M8 x 35 - ISO 4017		2
5	864.080.024	Large washer M8 - DIN 9021		2
6	830.080.080	Self Lock Nut M8 - ISO 10511		2
7	924.340.001	Decall adjustment valve		2
8	922.280.000	Decall funnel		1
9	921.280.402	Safety decall VS		2
10	922.260.428	Label Overseeder 1430		3
11	922.340.008	Decall fixation point		2

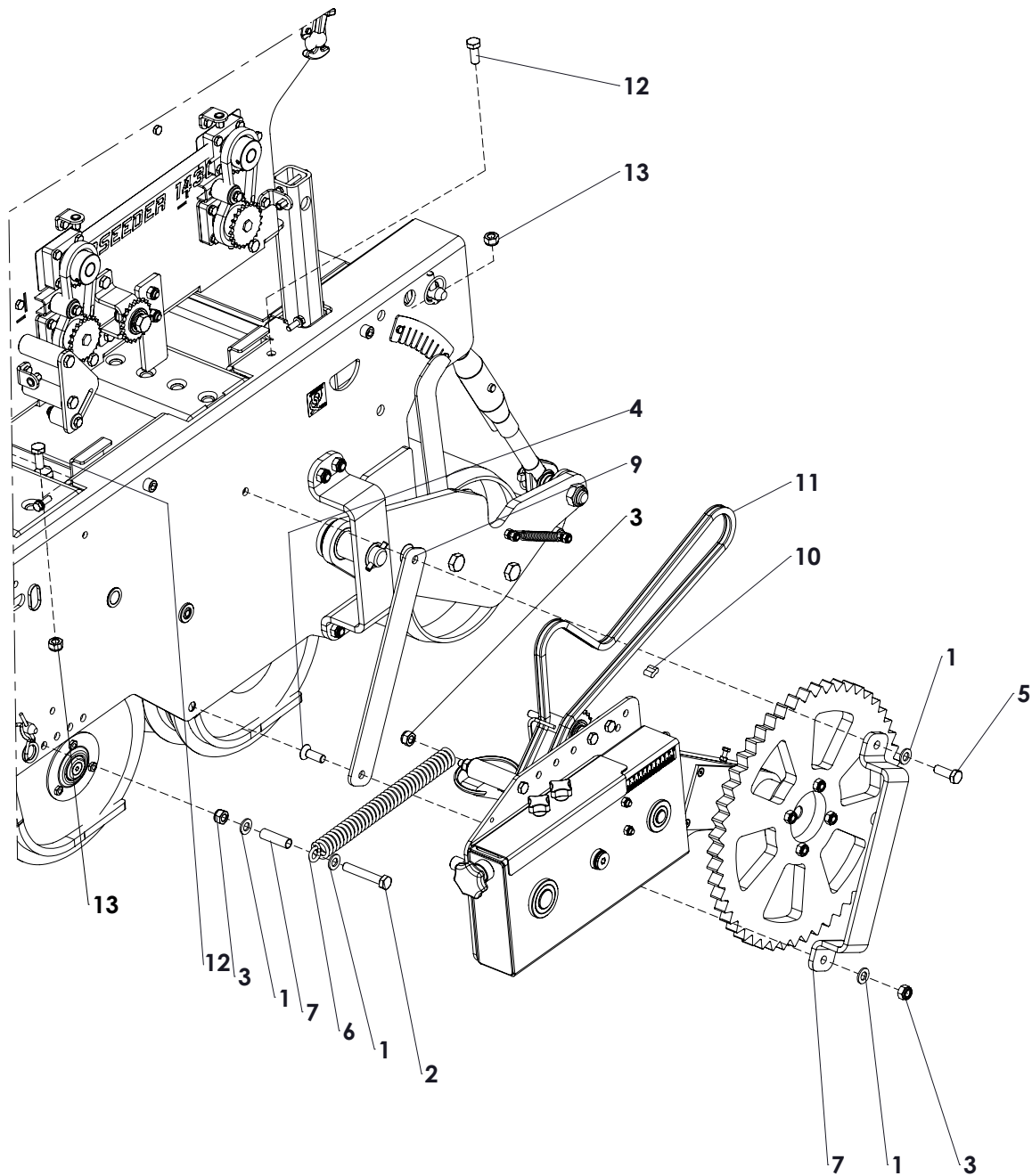

ITEM	PART NUMBER	DESCRIPTION	REMARKS	QUA
1	864.120.030	Washer M12 - ISO 7089		4
2	802.120.750	Bolt M12 x 75 - ISO 4014		1
3	830.120.120	Self Lock Nut M12 - ISO 10511 Class 10		5
4	816.120.350	Bolt M12 x 35- DIN 7991		1
5	804.120.350	Bolt M12 x 35 - ISO 4017		1
6	575.302.250	Spring wheelaxle		1
7	406.100.500	Distance bush spring wheel		1
8	468.084.150	Guide swingarm		1
9	444.054.100	Guide plate swingarm		1
10	638.090.090	Chain connector 3_8 inch 6B Simplex		1
11	631.001.680	Chain 3/8" L=1667		1
12	804.120.300	Bolt M12 x 30 - ISO 4017		2

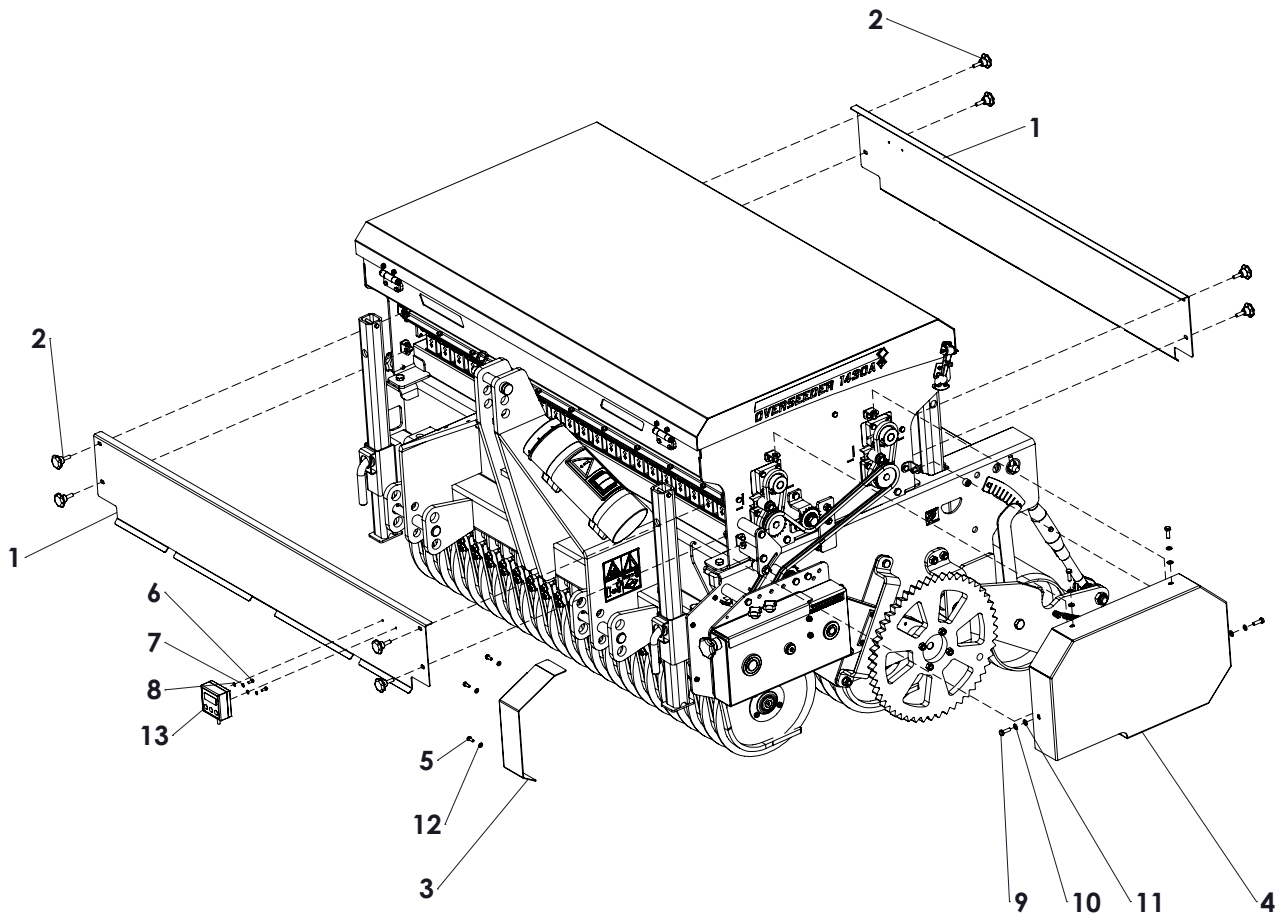

ITEM	PART NUMBER	DESCRIPTION	REMARKS	QUA
1	456.144.020	Cover		2
2	836.080.560	Knurled knob M8x40, L=25mm		8
3	456.041.011	Cover		1
4	468.025.910	Side cover		1
5	804.060.160	Bolt M6 x 16 - ISO 4017		3
6	804.050.120	Bolt M5 x 12 - ISO 4017		2
7	866.050.020	Spring Washer M5 - DIN 127		2
8	864.050.030	Washer M5 - ISO 7089		2
9	804.080.250	Bolt M8 x 25 - ISO 4017		4
10	866.080.020	Spring Washer M8 - DIN 127		4
11	864.080.030	Washer M8 - ISO 7089		4
12	864.060.030	Washer M6 - ISO 7089		3
13	569.390.780	Counter UC300		1

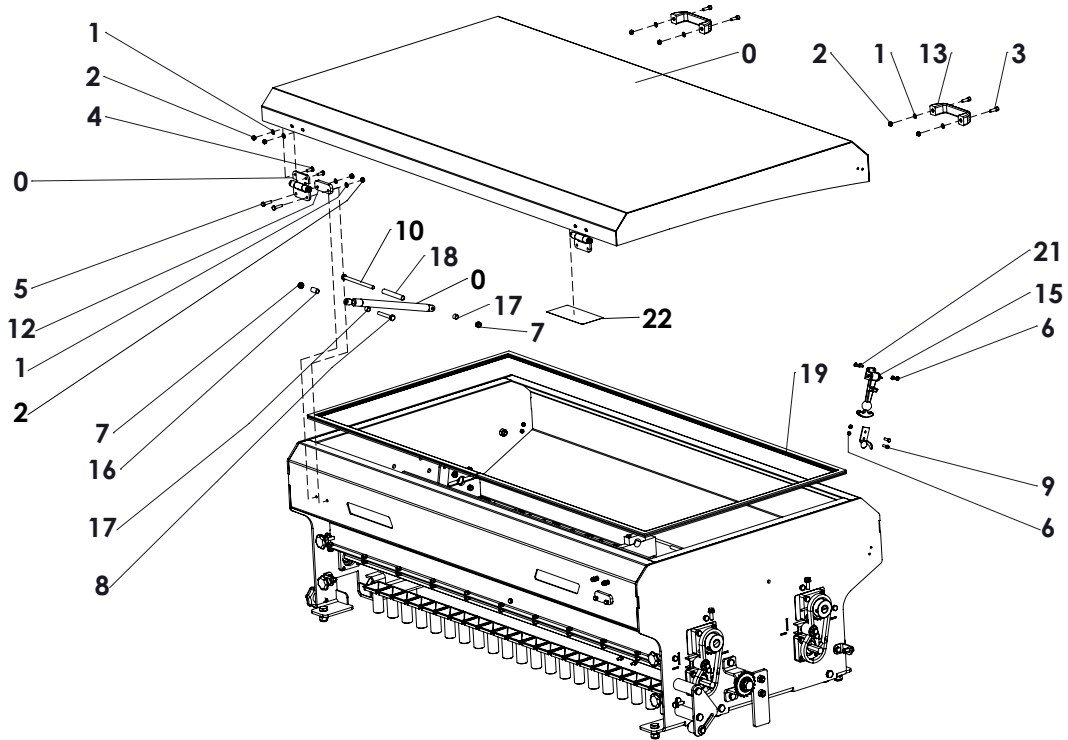

ITEM	PART NUMBER	DESCRIPTION	REMARKS	QUA
1	864.060.030	Washer M6 - ISO 7089		12
2	830.060.060	Self Lock Nut M6 - ISO 10511		12
3	814.060.200	Bolt M6 x 20 - DIN 912		4
4	804.060.160	Bolt M6 x 16 - ISO 4017		4
5	804.060.250	Bolt M6 x 25 - ISO 4017		4
6	830.050.050	Self Lock Nut M5 - ISO 10511		8
7	830.080.080	Self Lock Nut M8 - ISO 10511		4
8	802.080.550	Bolt M8 x 55 - ISO 4014		2
9	804.050.160	Bolt M5 x 16 - ISO 4017		4
10	802.081.200	Bolt M8 x 120 - ISO 4014		2
11	456.148.000	Seeder cover		1
12	464.080.650	Shim		2
13	444.151.250	Handle		2
14	571.224.856	Gas strut L=485/stroke=200 F=400N		2
15	590.650.000	Rubber lock assy		2
16	406.090.210	Distance bush Ø12 / Ø9 L=21		2
17	406.090.090	Distance bush Ø12 / Ø9 L=9		4
18	406.090.800	Distance bush Ø12 / Ø9 L=80		2
19	446.109.406	Rubber U-seal 1-4mm L=4060		1
20	899.100.634	Hinge		2
21	816.050.120	Bolt M5x12 - DIN 7991		4
22	924.280.000	Decal seed hopper		1

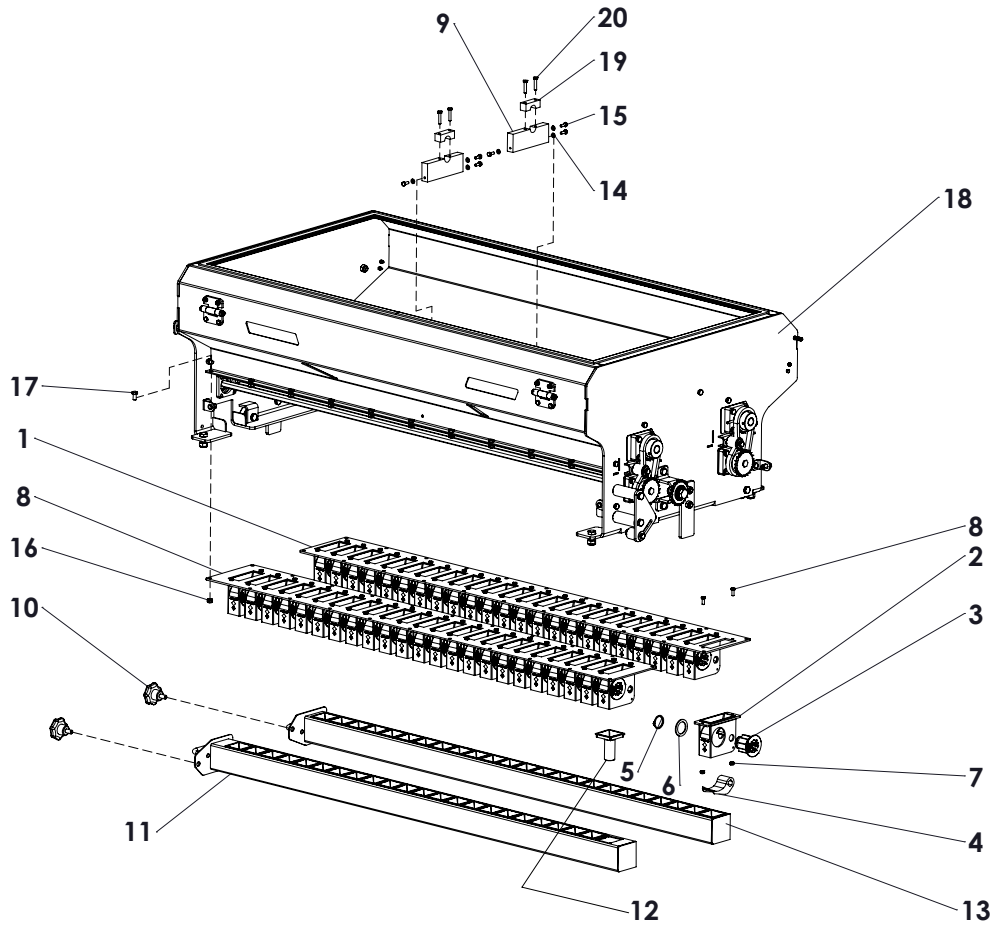

ITEM	PART NUMBER	DESCRIPTION	REMARKS	QUA
1	468.049.450	Rear plate		1
2	444.050.133	Seed element casing		47
3	444.058.510	Seed element rotor		47
4	444.034.760	Seed element valve		47
5	870.032.160	Circlip d=32 - DIN 471		47
6	412.020.450	Washer		47
7	830.060.060	Self Lock Nut M6 - ISO 10511		94
8	468.049.452	Front plate		1
9	444.201.440	Guide lock block		2
10	836.100.520	Knurled knob M10x20		2
11	494.151.016	Funnel beam front		1
12	444.520.710	Funnel DD overseeder		47
13	494.152.016	Funnel beam rear		1
14	864.060.030	Washer M6 - ISO 7089		6
15	804.060.160	Bolt M6 x 16 - ISO 4017		94
16	830.080.080	Self Lock Nut M8 - ISO 10511		74
17	804.080.160	Bolt M8 x 16 - ISO 4017		44
18	494.839.140	Hopper frame Overseeder 1430 II		1
19	444.200.550	Guide Block support		2
20	804.060.300	Bolt M6 x 30 - ISO 4017		4



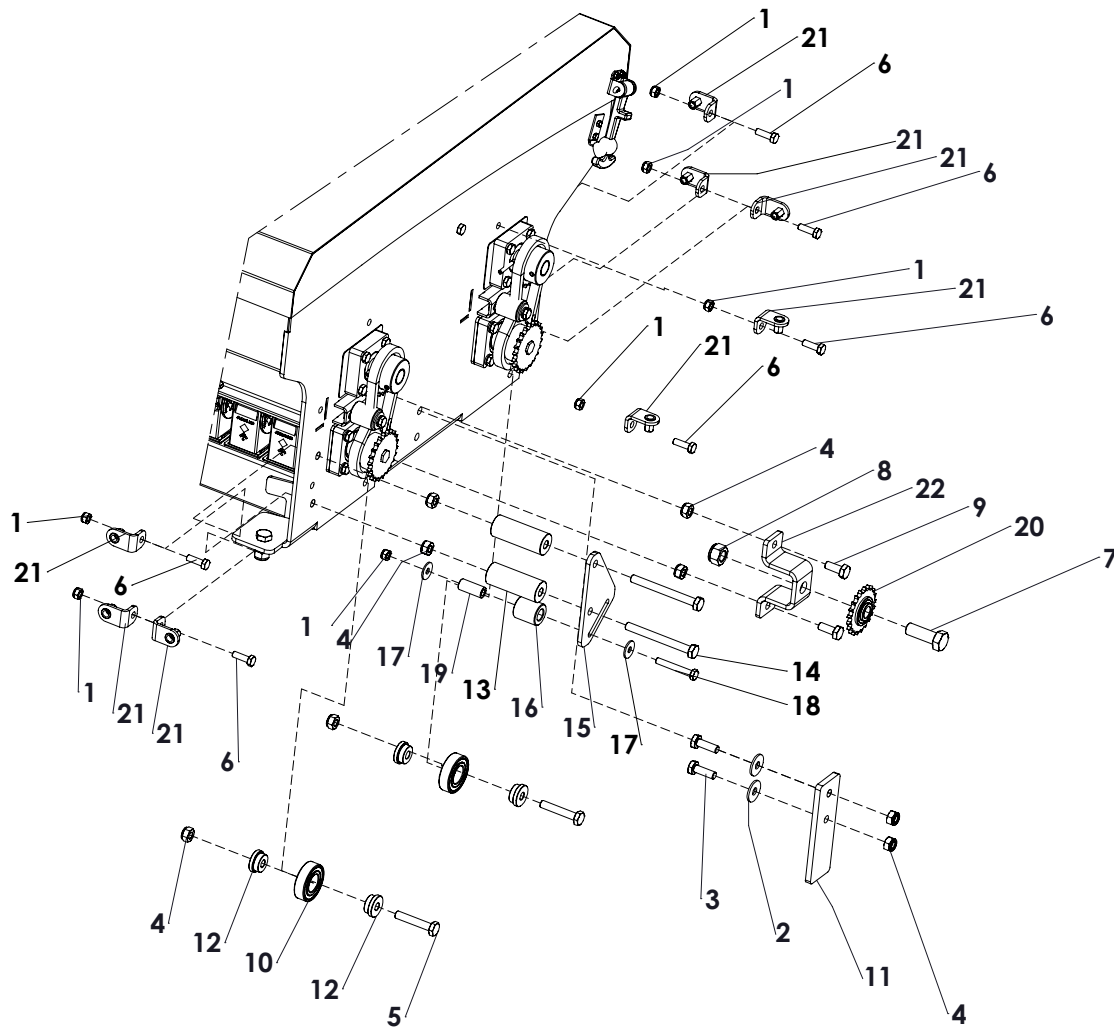

ITEM	PART NUMBER	DESCRIPTION	REMARKS	QUA
1	830.080.080	Self Lock Nut M8 - ISO 10511		7
2	864.100.031	Large washer M10 - DIN 9021		2
3	804.100.300	Bolt M10 x 30 - ISO 4017		2
4	830.100.100	Self Lock Nut M10 - ISO 10511		8
5	802.100.550	Bolt M10 x 55 - ISO 4014		2
6	804.080.250	Bolt M8 x 25 - ISO 4017		6
7	804.160.450	Bolt M16 x 45 - ISO 4017		1
8	830.160.160	Self Lock Nut M16-ISO 10511 Class 10		1
9	804.100.250	Bolt M10 x 25 - ISO 4017		2
10	713.250.150	Bearing 6205-LLU		2
11	464.081.504	End strip		1
12	404.100.136	Bearing Bush		4
13	406.110.770	Spacer		2
14	802.101.000	Bolt M10 x 100 - ISO 4014		2
15	470.061.442	Support plate		1
16	444.160.350	Roller		1
17	864.080.024	Large washer M8 - DIN 9021		2
18	802.080.550	Bolt M8 x 55 - ISO 4014		1
19	406.090.350	Distance bush Ø15/Ø8,5 L=35		1
20	638.000.690	Chain spanner 3/8" z=21		1
21	464.040.430	Bracket		7
22	468.040.304	Bracket		1

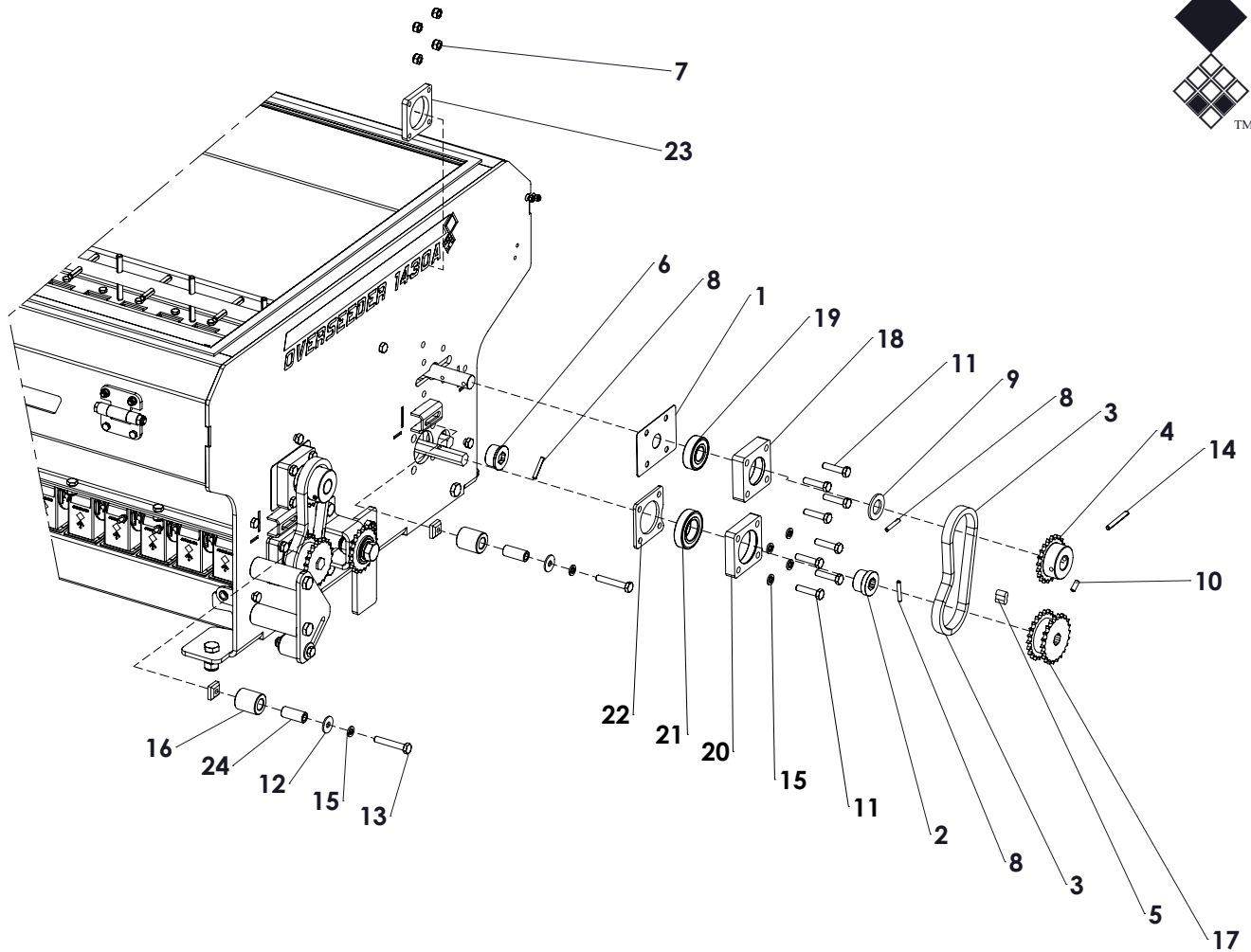

ITEM	PART NUMBER	DESCRIPTION	REMARKS	QUA
1	468.011.002	Cover plate		2
2	410.160.182	Bush		4
3	631.000.440	Chain 3/8", L=429		2
4	635.000.694	Sprocket 3/8"(06B) simplex 21Z		2
5	638.090.090	Chain connector 3_8 inch 6B Simplex		2
6	410.160.180	Bush		2
7	830.080.080	Self Lock Nut M8 - ISO 10511		8
8	878.050.320	Roll pin Ø5x32		6
9	864.200.030	Washer M20 - ISO 7089		2
10	818.060.160	Set screw M6 x 16 Din 913		2
11	802.080.350	Bolt M8 x 35 - ISO 4014		16
12	864.080.024	Large washer M8 - DIN 9021		2
13	802.080.500	Bolt M8 x 50 - ISO 4014		2
14	878.060.500	Roll Pin 6 x 50 - ISO 8752		2
15	866.080.020	Spring Washer M8 - DIN 127		10
16	444.160.350	Roller		2
17	638.000.360	Chainwheel weldment		2
18	468.180.704	Bearing block		2
19	713.200.140	Bearing 6204-C-2HRS		2
20	468.150.704	Bearing block		2
21	713.300.130	Bearing 6006 LLU		4
22	468.040.702	Plate		2
23	468.080.640	Contra plate		2
24	406.090.350	Distance bush Ø15/Ø8.5 L=35		2

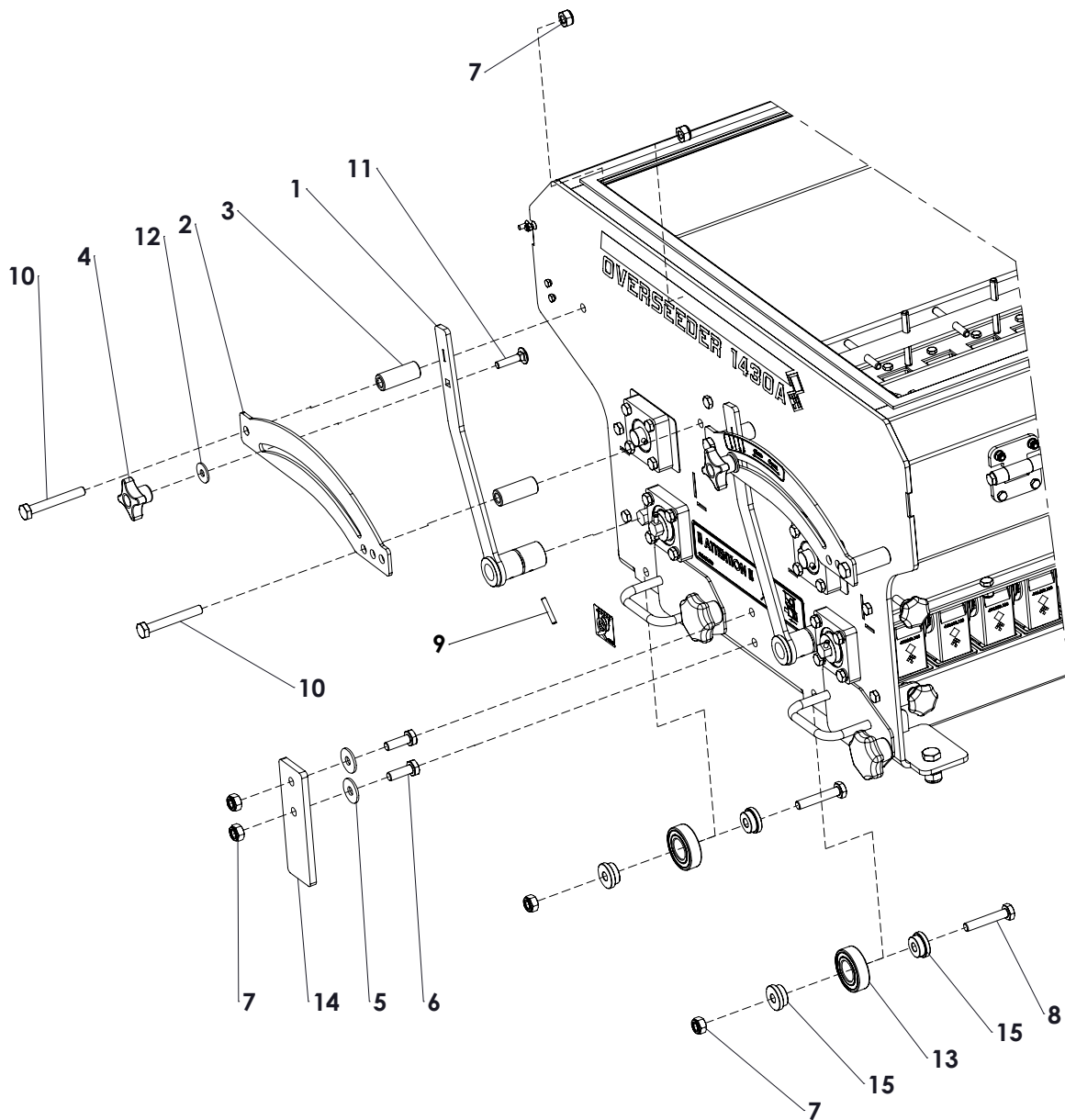

ITEM	PART NUMBER	DESCRIPTION	REMARKS	QUA
1	464.063.134	Valve adjustment		2
2	464.041.752	Guide strip		2
3	406.110.500	Distance bush Ø20/Ø10.5 L=50		4
4	836.080.260	Knob M8 - Din 6335		2
5	864.100.031	Large washer M10 - DIN 9021		2
6	804.100.300	Bolt M10 x 30 - ISO 4017		2
7	830.100.100	Self Lock Nut M10 - ISO 10511		4
8	802.100.550	Bolt M10 x 55 - ISO 4014		4
9	878.050.320	Roll pin Ø5x32		2
10	802.100.750	Bolt M10 x 75 - ISO 4014		4
11	820.080.350	MH Bolt M8 x 35 ISO 8677		2
12	864.080.024	Large washer M8 - DIN 9021		2
13	713.250.150	Bearing 6205-LLU		2
14	464.081.504	End strip		1
15	404.100.136	Bearing Bush		4

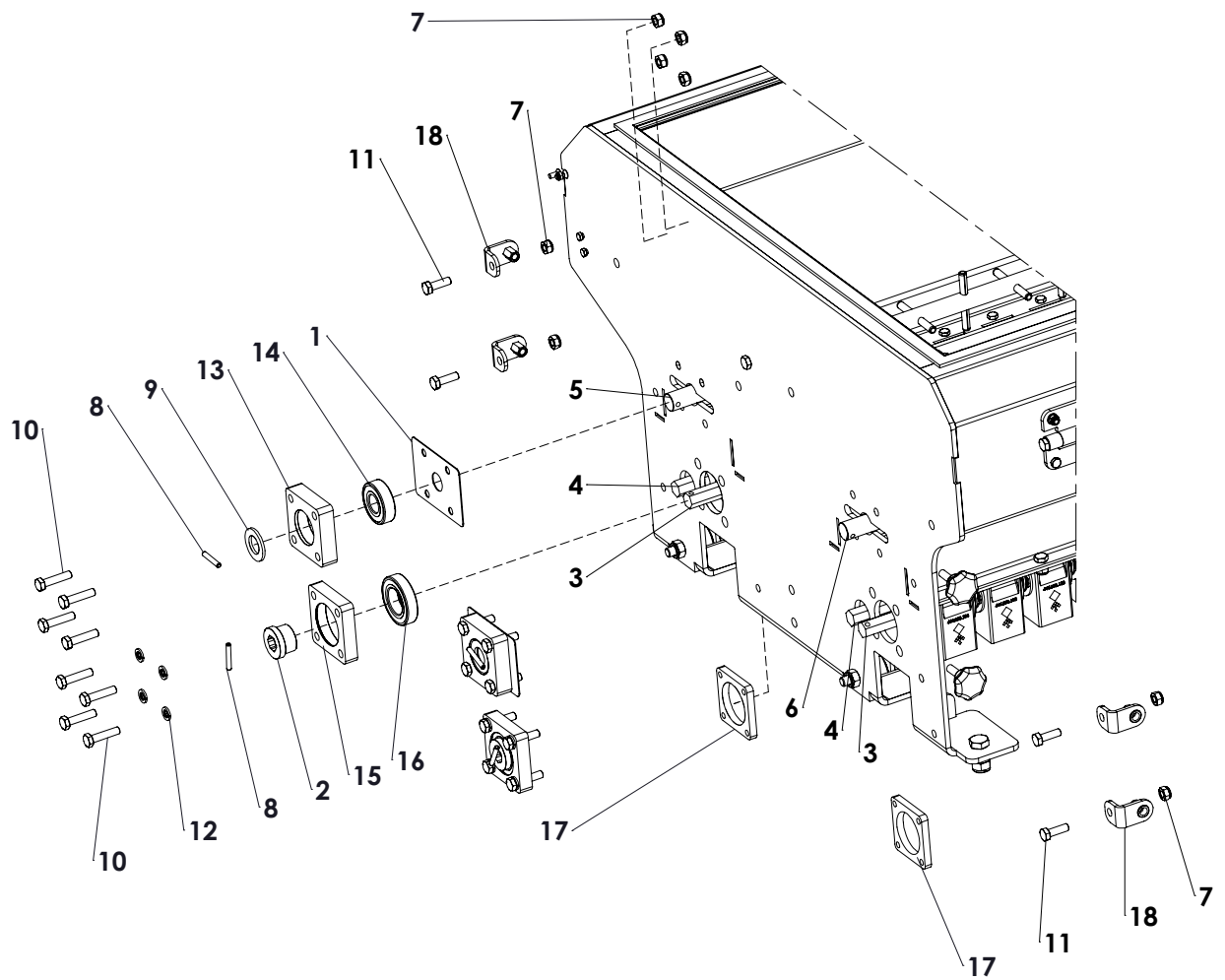

ITEM	PART NUMBER	DESCRIPTION	REMARKS	QUA
1	468.011.002	Cover plate		2
2	410.160.182	Bush		2
3	422.169.156	Shaft		2
4	422.149.191	Shaft		2
5	474.809.156	Agitator shaft rear		1
6	474.809.158	Agitator shaft front		1
7	830.080.080	Self Lock Nut M8 - ISO 10511		12
8	878.050.320	Roll pin Ø5x32		4
9	864.200.030	Washer M20 - ISO 7089		2
10	802.080.350	Bolt M8 x 35 - ISO 4014		16
11	804.080.250	Bolt M8 x 25 - ISO 4017		4
12	866.080.020	Spring Washer M8 - DIN 127		8
13	468.180.704	Bearing block		2
14	713.200.140	Bearing 6204-C-2HRS		2
15	468.150.704	Bearing block		2
16	713.300.130	Bearing 6006 LLU		2
17	468.080.640	Contra plate		2
18	464.040.430	Bracket		4

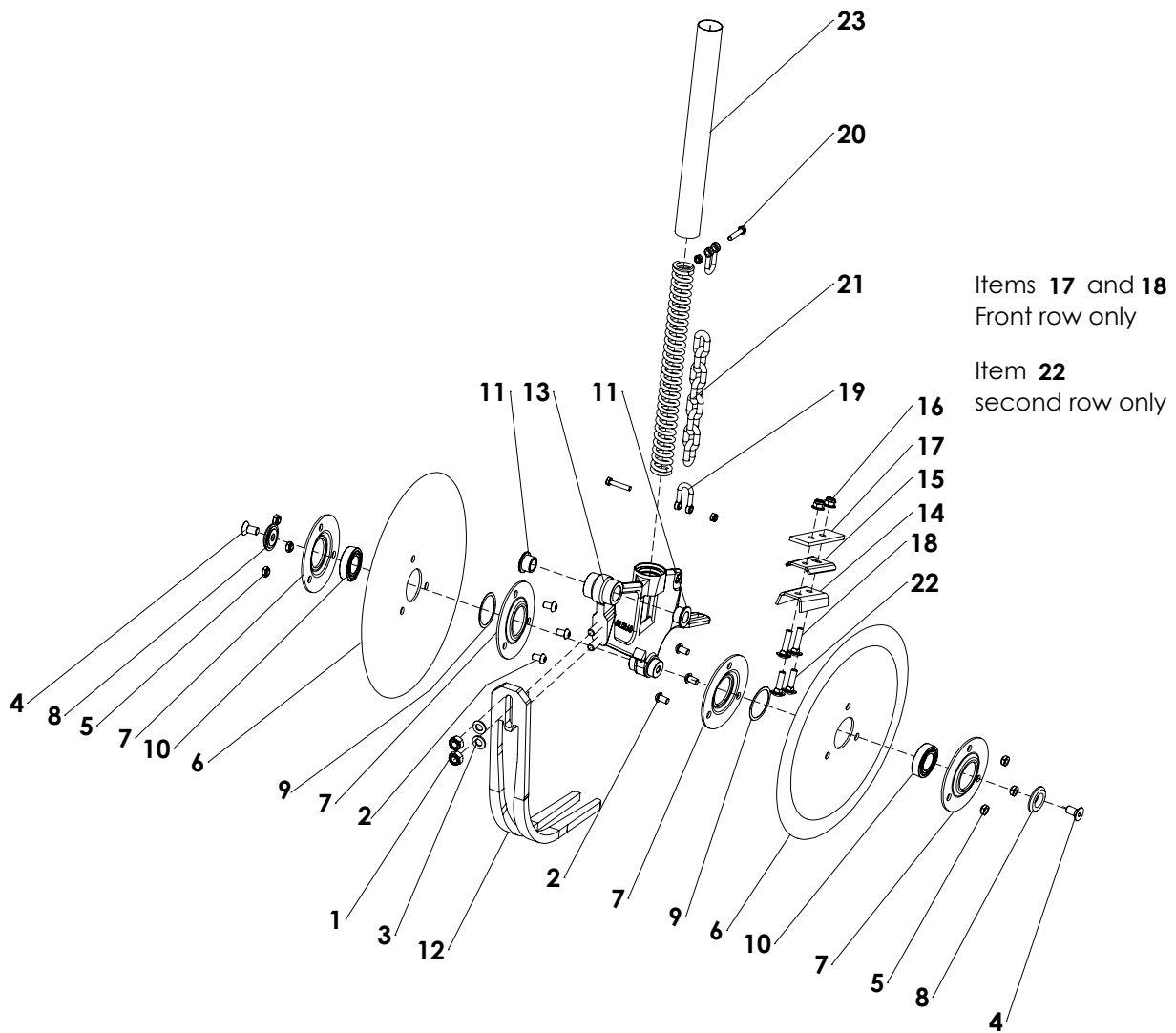

Items 17 and 18  
Front row only

Item 22  
second row only

ITEM	PART NUMBER	DESCRIPTION	REMARKS	QUA
1	830.100.100	Self Lock Nut M10 - ISO 10511		2
2	814.080.140	Bolt M8 x 14 - ISO 7380		6
3	864.100.030	Washer M10 - ISO 7089		2
4	816.100.202	Bolt M10 x 20 -10,9 DIN 7991		2
5	844.080.650	M8 KALEI nut		6
6	468.023.202	Cutting disk Ø320		2
7	468.031.104	Center plate		4
8	410.100.070	Lock bush Ø38		2
9	406.420.010	Shim 50x42 D=0.5mm		2
10	713.250.120	Bearing 6005-LLU		2
11	442.160.150	Bearing bush		2
12	468.123.260	Cutting guide		1
13	470.123.640	Seeding element		1
14	444.020.750	Rubber scraper		1
15	468.030.752	Scraper strip		1
16	830.080.085	Self lock nut M8 - ISO 7043		2
17	464.051.120	Strip	Front row only	1
18	820.080.350	MH Bolt M8 x 35 ISO 8677	Front row only	2
19	846.060.380	D-Shackle Ø6		1
20	824.060.320	Special bolt M6x32		1
21	899.082.000	Chain seeding element 8-links D=8mm L=200 (±7.9")		1
22	820.080.300	MH Bolt M8 x 30 ISO 8677	Second row only	2
23	444.403.200	Spring hose L=320mm		1

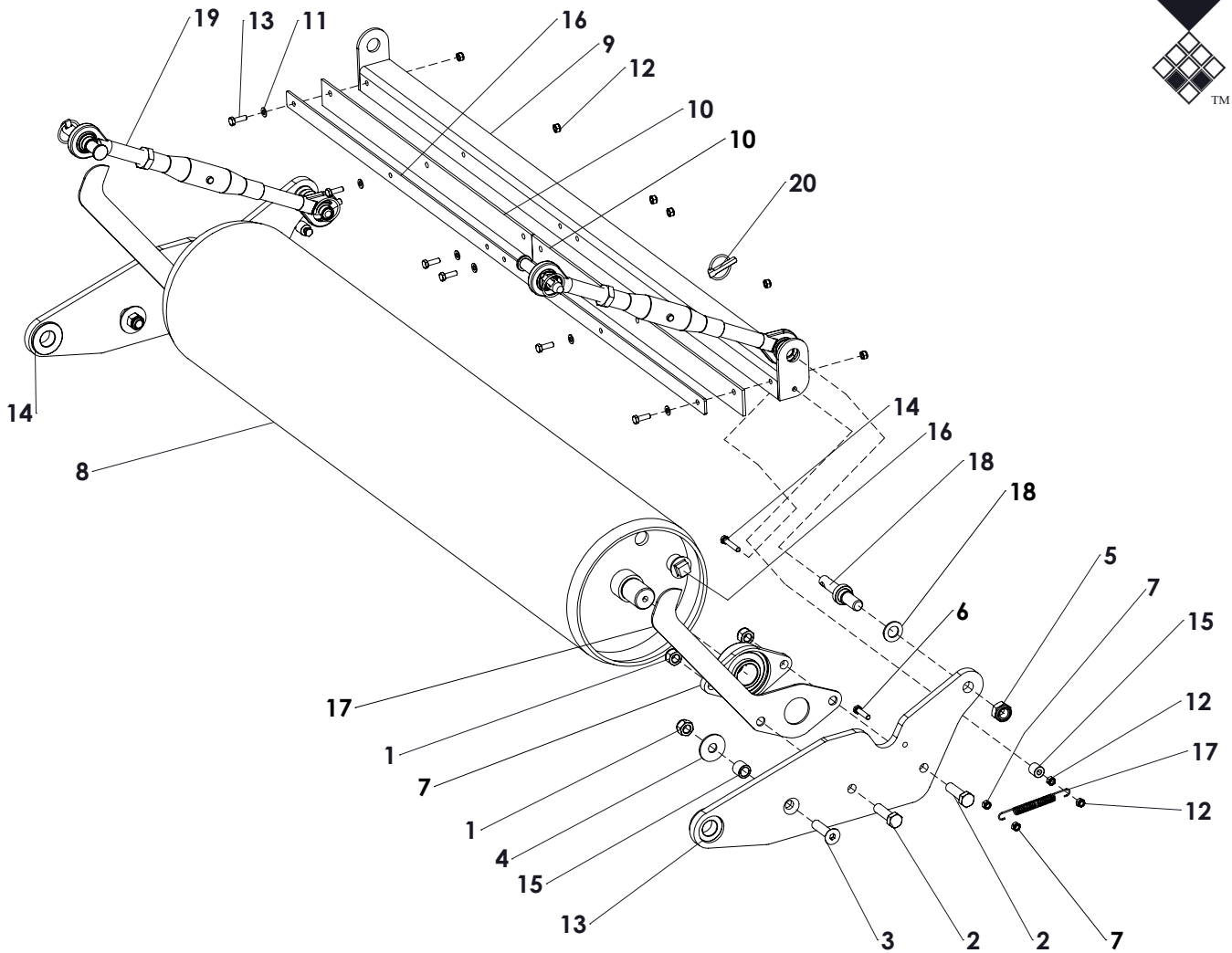

ITEM	PART NUMBER	DESCRIPTION	REMARKS	QUA
1	830.160.160	Self Lock Nut M16-ISO 10511 Class 10		6
2	802.160.550	Bolt M16 x 55		4
3	816.160.600	Bolt M16 x 60 - DIN 7991		2
4	864.160.031	Large washer M16 - DIN 9021		2
5	830.200.200	Self Lock Nut M20 Din 985 h=17		2
6	804.080.350	Bolt M8 x 35 - ISO 4017		2
7	742.400.520	Bearing UCFL 208		2
8	488.273.148	Rear roller		1
9	466.059.149	Rear roller scraper		1
10	444.057.400	Scraper plate		2
11	864.080.030	Washer M8 - ISO 7089		6
12	830.080.080	Self Lock Nut M8 - ISO 10511		14
13	804.080.250	Bolt M8 x 25 - ISO 4017		6
14	804.080.450	Bolt M8 x 45 - ISO 4017		2
15	402.080.220	Bush Ø20/Ø8.5 L=20		2
16	468.049.147	Lock strip		1
17	575.141.100	Tension spring		2
18	864.200.030	Washer M20 - ISO 7089		2
19	522.194.370	Toplink Cat. 1 L0=370 Stroke=200 M24x3		2
20	523.100.570	Linch Pin d10		2

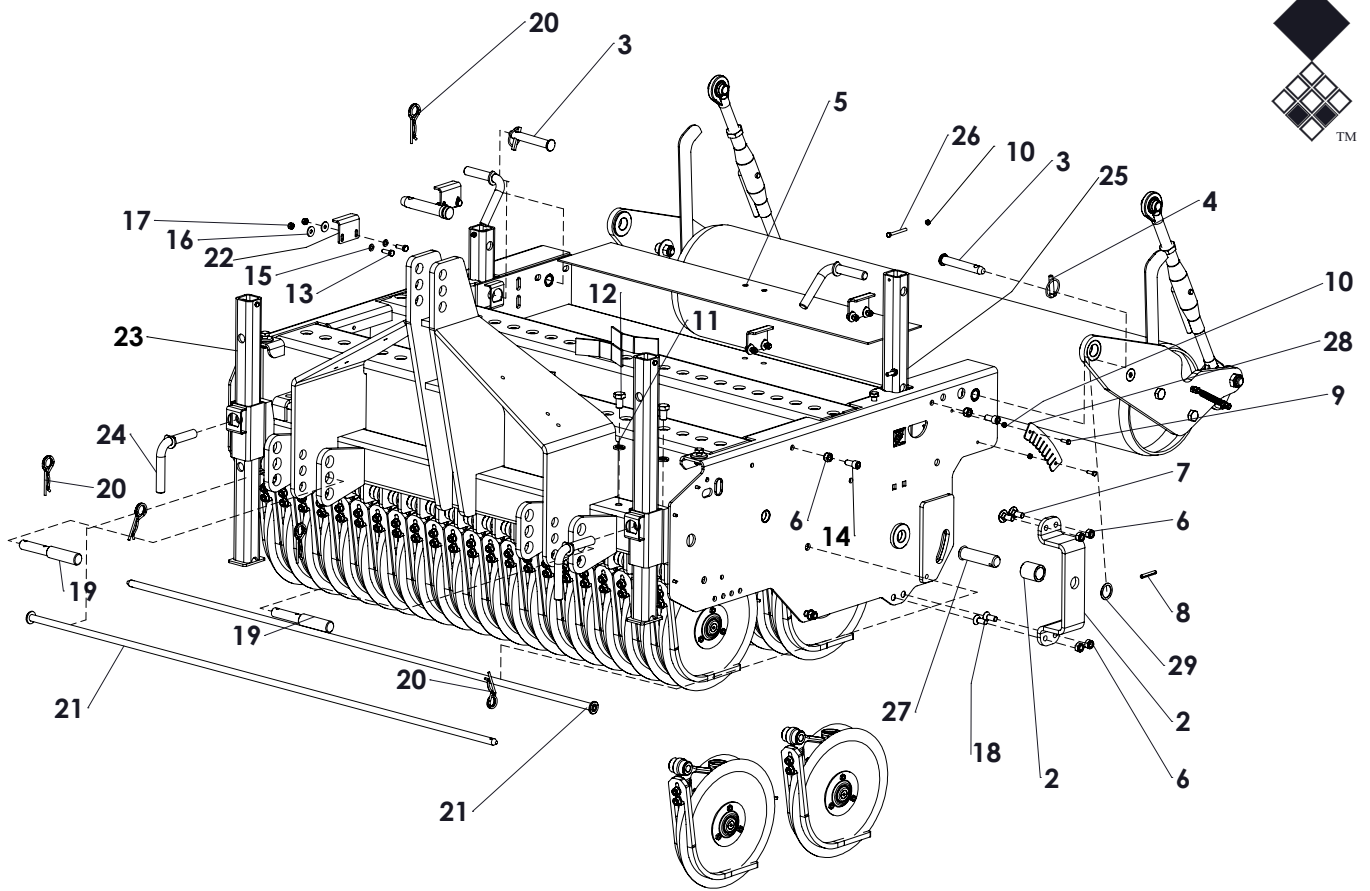

ITEM	PART NUMBER	DESCRIPTION	REMARKS	QUA
1	468.103.150	Bracket		2
2	402.290.450	Bush		2
3	521.191.300	Top Link Pin Ø19 L=105		2
4	523.100.570	Linch Pin d10		4
5	446.049.120	Rubber grip plate		1
6	830.120.120	Self Lock Nut M12 - ISO 10511 Class 10		12
7	820.120.300	MH Bolt M12 x 30 ISO 8677		4
8	878.080.500	Roll Pin 8 x 50 - ISO 8752		2
9	804.060.200	Bolt M6 x 20 - ISO 4017		4
10	830.060.060	Self Lock Nut M6 - ISO 10511		4
11	866.160.020	Spring Washer M16 - DIN 127		8
12	804.160.250	Bolt M16 x 25 - ISO 4017		2
13	804.080.250	Bolt M8 x 25 - ISO 4017		8
14	814.120.250	Bolt M12 x 25 - DIN 912		4
15	864.080.030	Washer M8 - ISO 7089		8
16	864.080.024	Large washer M8 - DIN 9021		8
17	830.080.080	Self Lock Nut M8 - ISO 10511		8
18	816.120.300	Bolt M12 x 30 - DIN 7991		4
19	521.221.600	3-point pin		2
20	523.051.000	R-clip Round 5, DIN 11024		5
21	474.169.150	Seeding element shaft		2
22	468.040.700	Lock bracket		4
23	462.050.655	Leg overseeder		2
24	474.201.320	Lock pin		4
25	462.050.770	Rear leg overseeder		2
26	802.060.600	Bolt M6 x 60 - ISO 4014		4
27	418.291.080	Pin Ø28.5 -Ø35 L=108		2
28	468.031.610	Indicator		2
29	868.040.100	Shim Ø30xØ40x1.0 DIN988		2

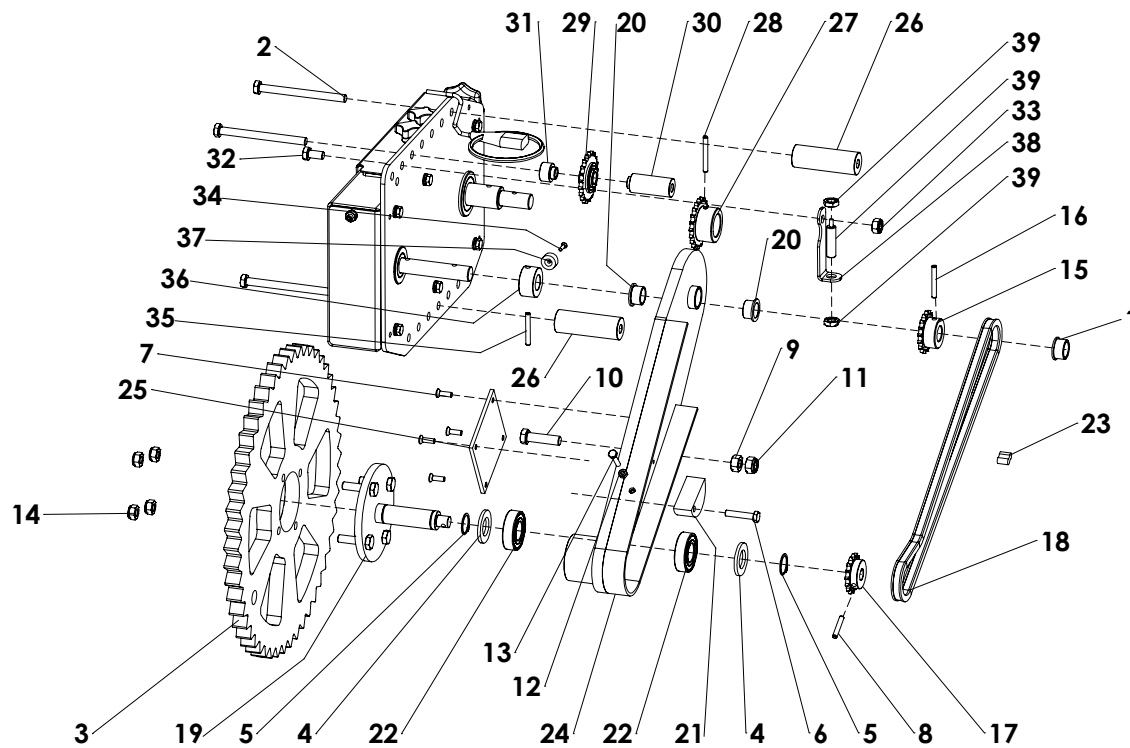

ITEM	PART NUMBER	DESCRIPTION	REMARKS	QUA
1	442.200.150	Bearing bush gearaxle		1
2	802.101.200	Bolt M10 x 120 - ISO 4014		3
3	468.204.202	Drive wheel		1
4	864.240.044	Washer M24 - ISO 7089		2
5	870.025.120	Circlip d=25 - DIN 471		2
6	802.080.400	Bolt M8 x 40 - ISO 4014		1
7	816.060.200	Bolt M6 x 20 - DIN 7991		4
8	878.060.350	Roll Pin 6 x 35 - ISO 8752		1
9	826.120.120	Nut M12 - DIN 934		1
10	802.120.450	Bolt M12 x 45 ISO 4014 Class 10.9		1
11	830.120.120	Self Lock Nut M12 - ISO 10511 Class 10		1
12	826.060.060	Nut M6 - DIN 934		1
13	804.060.300	Bolt M6 x 30 - ISO 4017		1
14	830.100.100	Self Lock Nut M10 - ISO 10511		4
15	635.000.572	Sprocket 3/8" (06B) simplex 17Z		1
16	878.060.450	Roll Pin 6 x 45 - ISO 8752		1
17	635.000.540	Sprocket 3/8" (06B) simplex 16Z		1
18	631.000.978	Chain 3/8" Simplex L=978		1
19	474.251.400	Wheel hub		1
20	442.200.152	Bearing bush swingarm		2
21	444.250.600	Chain tensioner		1
22	713.250.150	Bearing 6205-LLU		2
23	638.090.090	Chain connector 3_8 inch 6B Simplex		1
24	466.155.000	Frame swingarm		1
25	444.051.000	Guide plate swingarm		1
26	406.110.880	Bush		2
27	635.000.680	Sprocket 3/8" (06B) simplex 21Z		1
28	878.060.500	Roll Pin 6 x 50 - ISO 8752		1
29	638.000.690	Chain spanner 3/8" z=21		1
30	404.100.570	Bush		1
31	404.110.130	Bush		1
32	804.100.200	Bolt M10 x 20 - ISO 4017		1
33	830.100.100	Self Lock Nut M10 - ISO 10511		1
34	816.040.160	Bolt M4 x 16 - DIN 7991		1
35	878.060.450	Roll Pin 6 x 45 - ISO 8752		1
36	406.200.204	Magnet bush		1
37	569.200.100	Magnet		1
38	468.030.980	Sensor bracket		1
39	569.100.430	Magnetic sensor D10 + cable + magnet		1



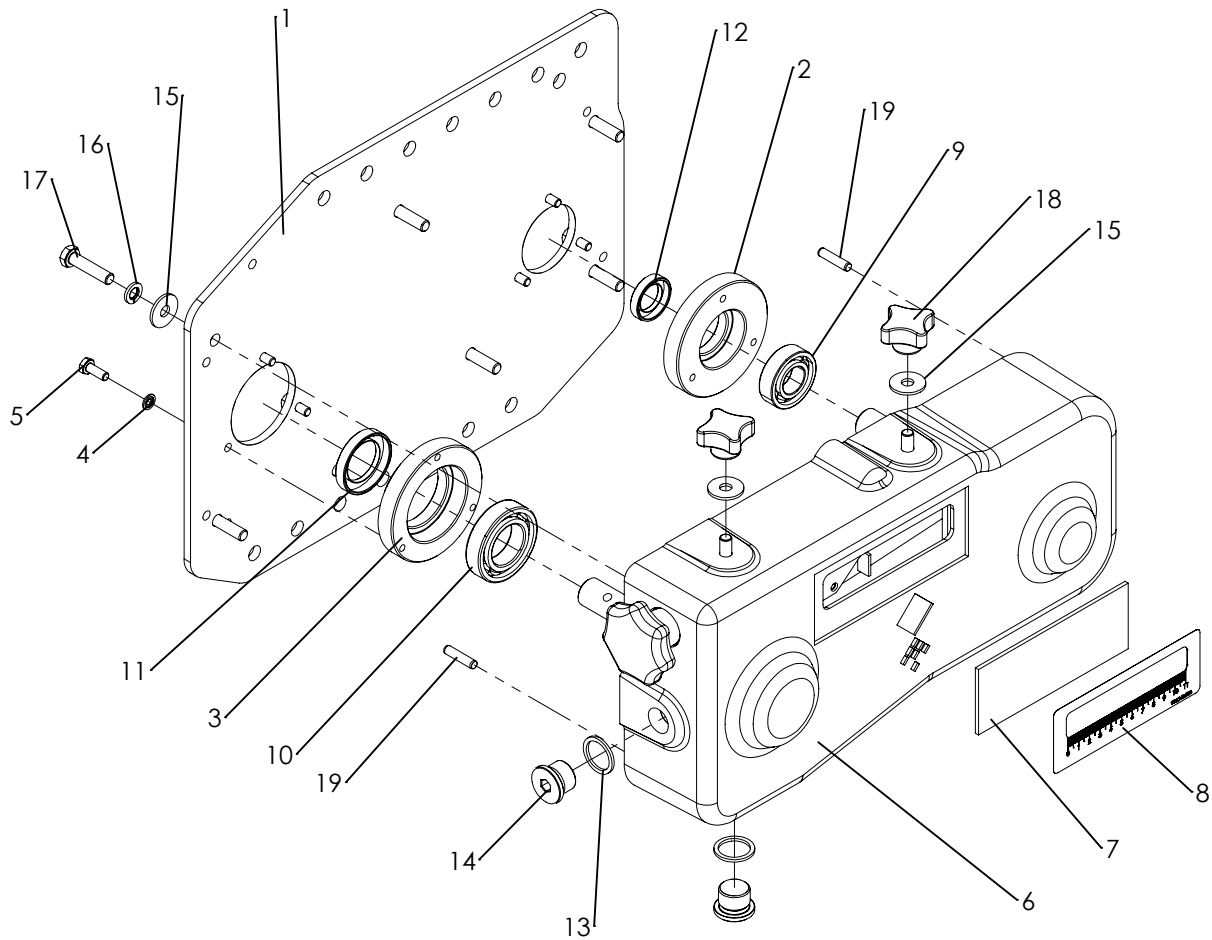

ITEM	PART NUMBER	DESCRIPTION	REMARKS	QUA
1	468.064.060	Lid plate		1
2	434.210.850	Bearing hub Ø42		1
3	434.230.850	Bearing hub Ø55		1
4	874.060.020	Bonded seal ring M6		6
5	804.060.160	Bolt M6 x 16 - ISO 4017		6
6	448.380.800	Casted gearbox housing		1
7	444.021.380	Window		1
8	934.140.510	Gauge decall		1
9	711.200.120	Bearing 6004		2
10	711.300.132	Bearing 6006		2
11	762.300.080	Oil seal 30-45-8		1
12	762.200.070	Oil seal 20-32-7		1
13	874.210.020	Copper washer 1_2		2
14	549.210.200	Blind plug G1/2		2
15	864.080.024	Large washer M8 - DIN 9021		9
16	866.080.020	Spring Washer M8 - DIN 127		7
17	804.080.350	Bolt M8 x 35 - ISO 4017		7
18	836.080.402	Closed Knob M8 - Din 6335		2
19	876.060.260	Parallel pin ISO 8734 - 6 x 26		2
	623.200.400	Gearbox complete		

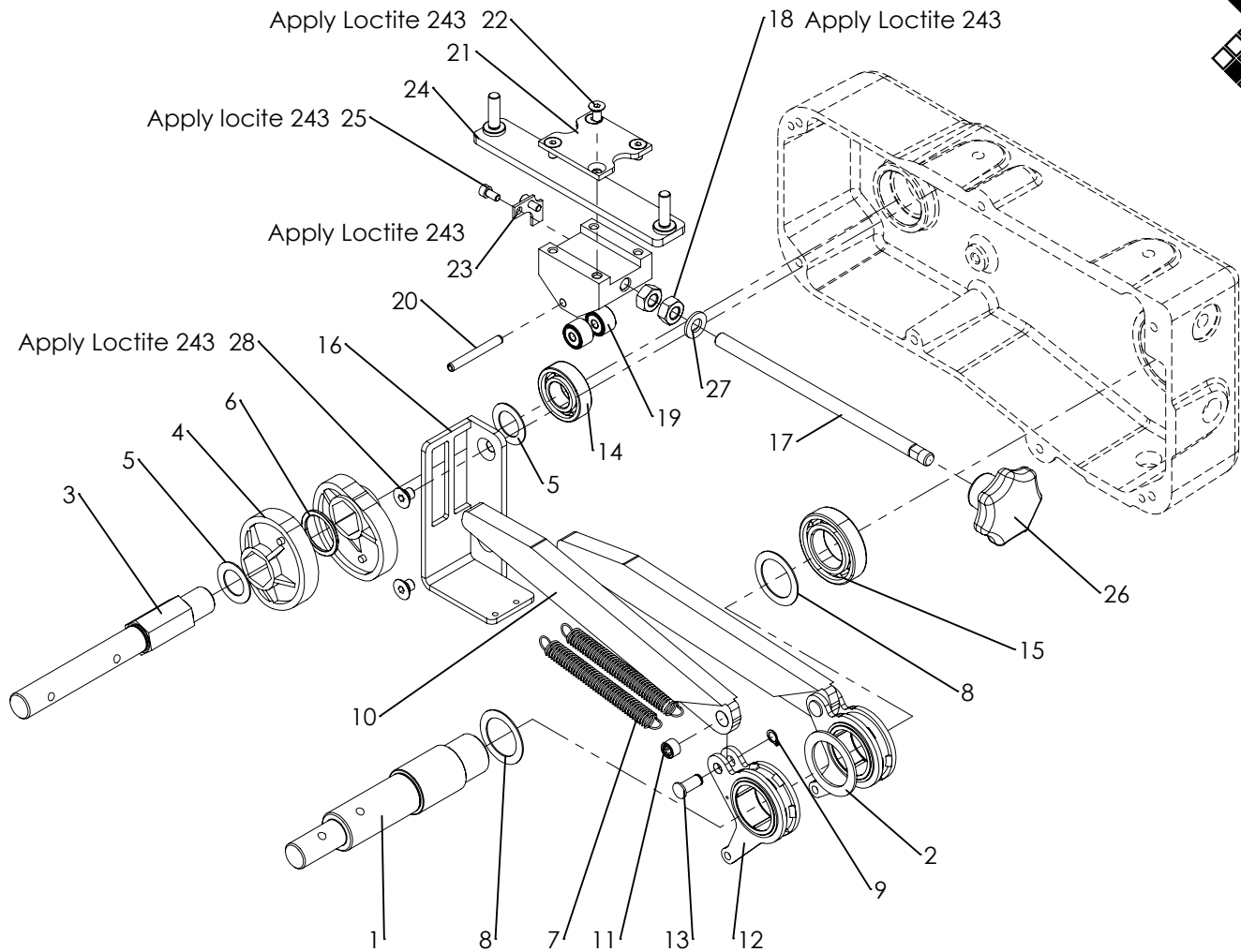

ITEM	PART NUMBER	DESCRIPTION	REMARKS	QUA
1	422.351.382	Shaft		1
2	444.020.500	Washer		1
3	422.242.020	Shaft		1
4	444.200.730	Excenter		2
5	868.032.100	Shim Ø20xØ32x1.0 DIN988	Quantity depending on clearance	
6	406.280.030	Spacer		1
7	575.010.800	Spring		2
8	868.042.100	Shim Ø30xØ42x1.0 DIN988	Quantity depending on clearance	
9	870.008.080	Circlip d=8 - DIN 471		2
10	464.152.702	Rocker strip		2
11	721.080.080	Bearing HK0808		2
12	442.200.980	Rocker arm assembly		2
13	418.080.200	Pin		2
14	711.200.120	Bearing 6004		1
15	711.300.132	Bearing 6006		1
16	470.120.550	Guide		1
17	852.102.100	Threaded rod M10x210		1
18	826.100.100	Nut M10 - DIN 934		2
19	721.060.120	Roller bearing		2
20	878.060.500	Roll Pin 6 x 50 - ISO 8752		1
21	468.040.530	Lock plate		1
22	816.060.122	Bolt M6 x 12 - DIN 7991		4
23	468.020.490	Indicator		1
24	468.061.620	Slider bracket		1
25	814.050.100	DIN 912 M5 x 10 --- 10C		2
26	836.100.630	Knob M10 with set screw		1
27	864.100.030	Washer M10 - ISO 7089		1
28	816.080.100	Bolt M8 x 10 - DIN 7991		2

**Timing, Spindle adjustment and Oil level**

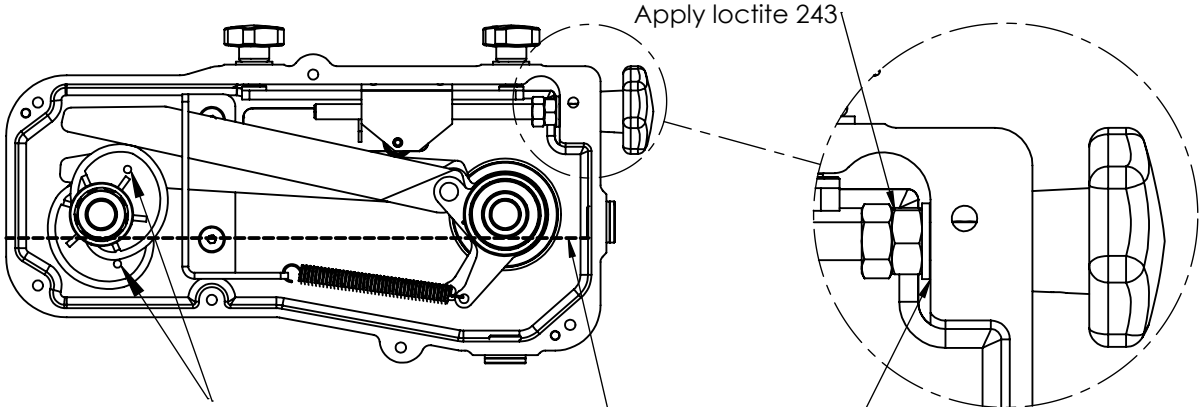

Warning! Make sure the excenters are positioned correct:

- The nodge has to be faced outwards.
- Timing: 180° shifted from each other

If not correctly installed a shocked rotation will occur at the output shaft.

Keep  $\pm 2\text{mm}$  (0.08") clearance distance between washer and casing!  
Adjustment must rotate smooth.

Fill gearbox with  $\pm 1,4\text{L}$  (0.37gal.) 80W90 oil  
Fill till oil level line (Bottom level plug)

**Axial clearance**

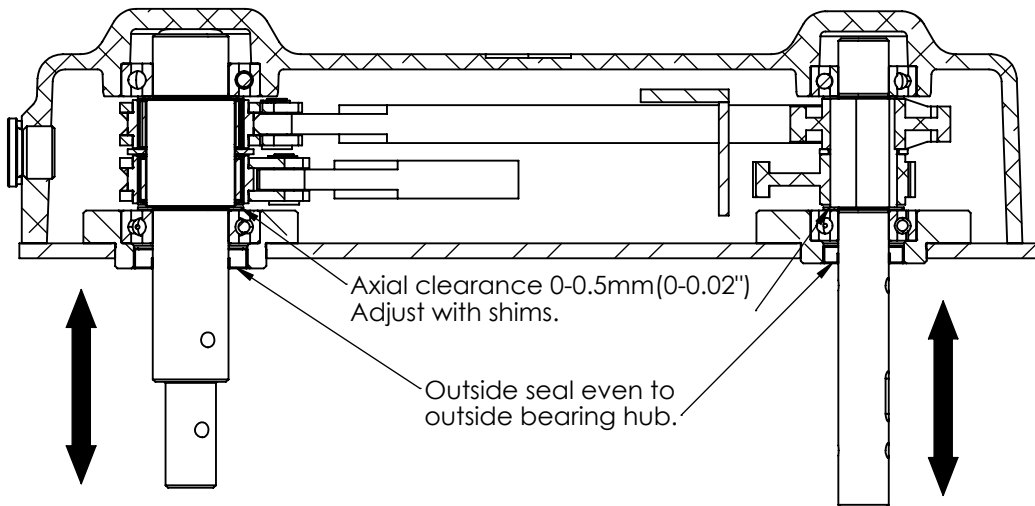

**Sealing plan**

1. Put sealing paste (Loctite 5970) on the gearbox housing according to the closed line as shown on the pictures below.
2. Make sure to put sealing paste around the threaded holes.
3. Make sure to clean the edges from excess sealant.

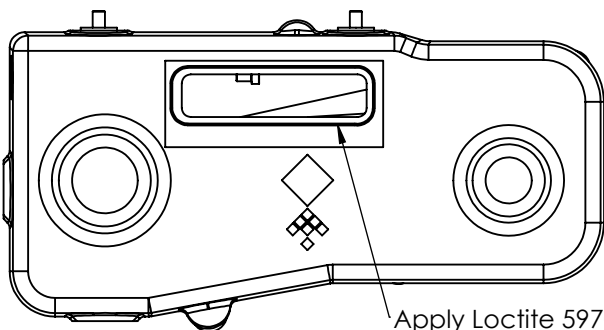

Apply Loctite 5970 (acid free sealing paste)

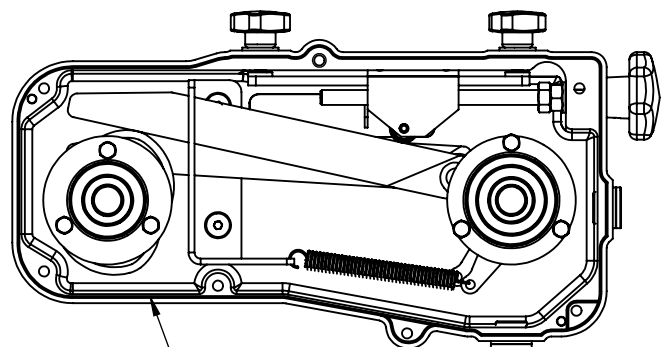

Apply Loctite 5970 (acid free sealing paste)

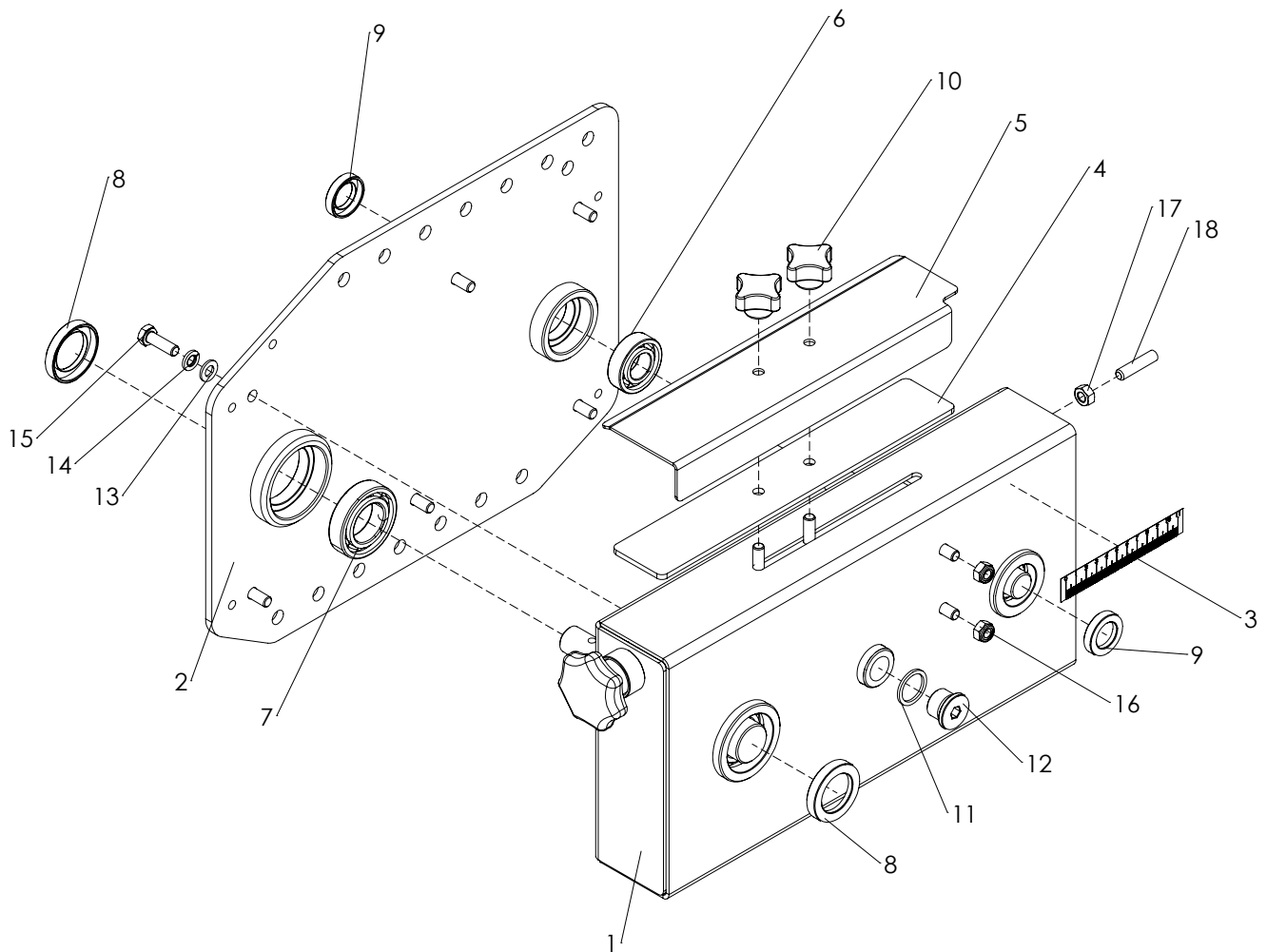

ITEM	PART NUMBER	DESCRIPTION	REMARKS	QUA
1	470.034.052	Gearbox housing		1
2	470.064.004	Gearbox lid		1
3	922.340.014	Gauge decall		1
4	444.032.900	Slider seal		1
5	468.022.900	Indicator		1
6	711.200.120	Bearing 6004		1
7	711.300.132	Bearing 6006		1
8	762.300.080	Oil seal 30-45-8		2
9	762.200.070	Oil seal 20-32-7		2
10	836.080.402	Closed Knob M8 - Din 6335		2
11	874.210.020	Copper washer 1_2		1
12	549.210.200	Blind plug G1/2		1
13	864.080.030	Washer M8 - ISO 7089		6
14	866.080.020	Spring Washer M8 - DIN 127		6
15	804.080.250	Bolt M8 x 25 - ISO 4017		6
16	830.080.080	Self Lock Nut M8 - ISO 10511		2
17	826.080.080	Nut M8 - DIN 934		1
18	818.080.350	Set screw M8x35 - DIN 913		1
	623.246.405	Gearbox complete		

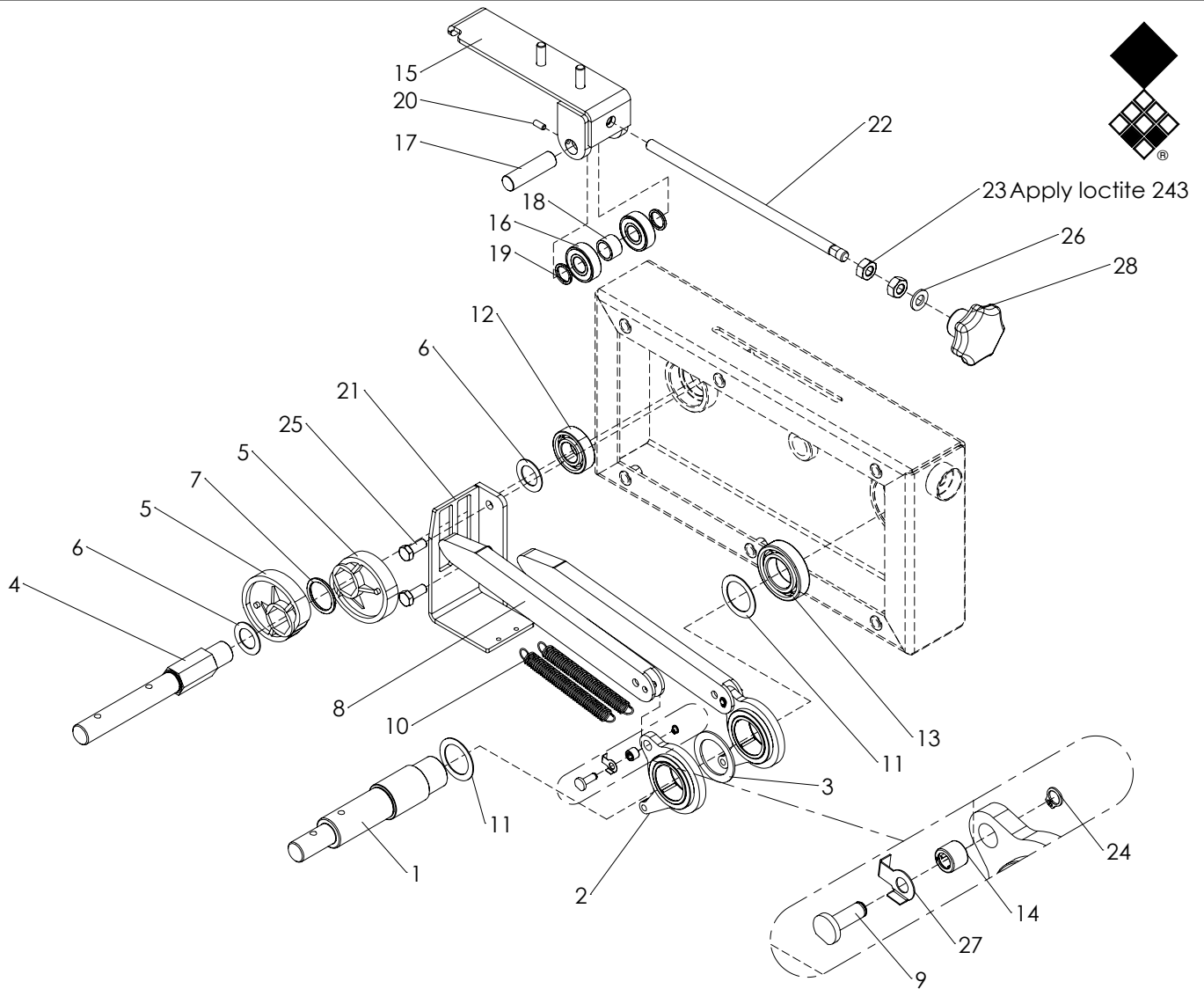

ITEM	PART NUMBER	DESCRIPTION	REMARKS	QUA
1	422.351.382	Shaft		1
2	478.019.101	Pivot point		1
3	444.020.500	Washer		1
4	422.242.020	Shaft		1
5	444.200.730	Excenter		2
6	868.032.100	Shim Ø20xØ32x1.0 DIN988	Quantity depending on clearance	
7	406.280.030	Spacer		1
8	464.152.600	Swing arm		2
9	418.060.190	Pin		2
10	575.010.800	Spring		2
11	868.042.100	Shim Ø30xØ42x1.0 DIN988	Quantity depending on clearance	
12	711.200.120	Bearing 6004		1
13	711.300.132	Bearing 6006		1
14	721.060.080	Bearing HK0608		2
15	470.041.980	Slider bracket		1
16	713.150.110	Bearing 6202-LLU		2
17	414.150.550	Shaft		1
18	406.150.132	Bush		1
19	406.150.020	Bush		2
20	818.050.120	Set screw M5 x 12 - DIN 913		2
21	470.041.190	Guide		1
22	852.102.500	Threaded rod M10x250		1
23	826.100.100	Nut M10 - DIN 934		2
24	870.006.070	Circlip d=6 - DIN 471		2
25	804.080.200	Bolt M8 x 20 - ISO 4017		2
26	864.100.030	Washer M10 - ISO 7089		1
27	874.060.240	Lock washer		2
28	836.100.630	Knob M10 with set screw		1

**Timing, Spindle adjustment and Grease level**

Adjust till max. output is 4:1

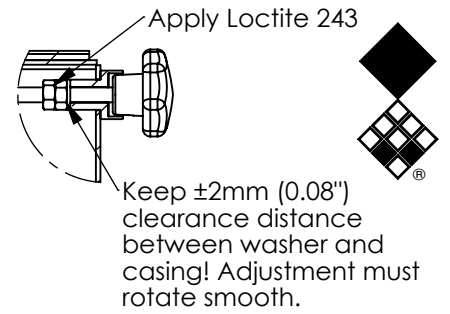
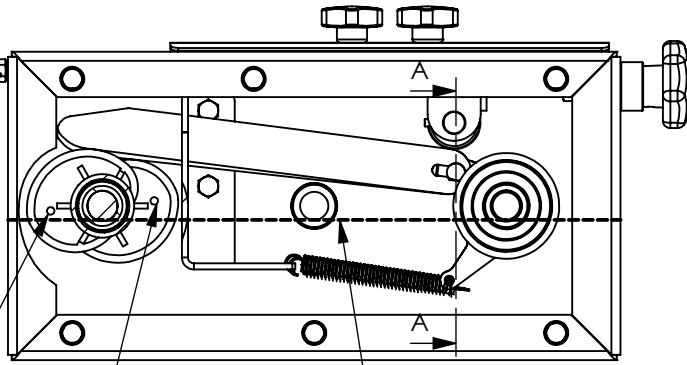

**SECTION A-A**  
Place pins from correct side and fold lock plate.

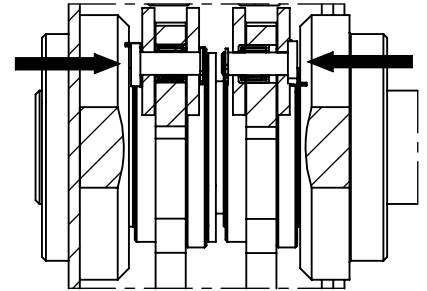

Warning! Make sure the excenters are positioned correct: Fill gearbox with  $\pm 2.8\text{kg}$  (6.17lbs.) EP0 grease  
Fill till level line (Bottom level plug)

- The nodge has to be faced outwards.
- Timing:  $180^\circ$  shifted from each other.

If not correctly installed a shocked rotation will occur at the output shaft.

**Axial clearance**

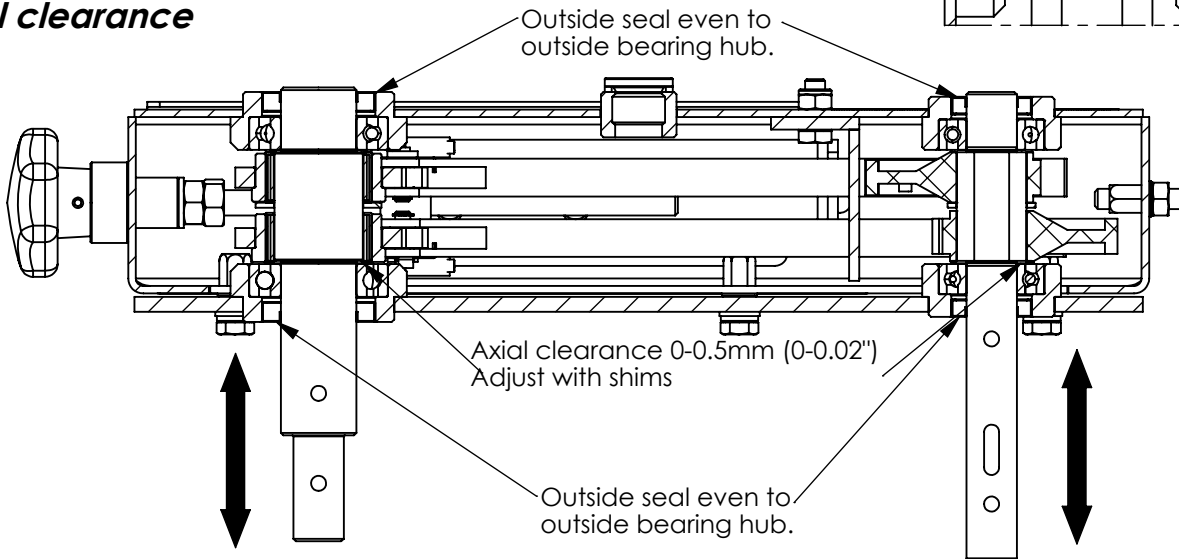

**Sealing plan**

1. Place sealing paste (Loctite 5970) on gearbox housing as shown in the pictures below. When the guide (1) is removed also apply sealant to the bolts.
2. Place gearbox lid on gearbox housing.
3. Fill bolt holes with silicone sealing before mounting the bolts of the gearbox lid.
4. Make sure to clean the edges of excess sealant.

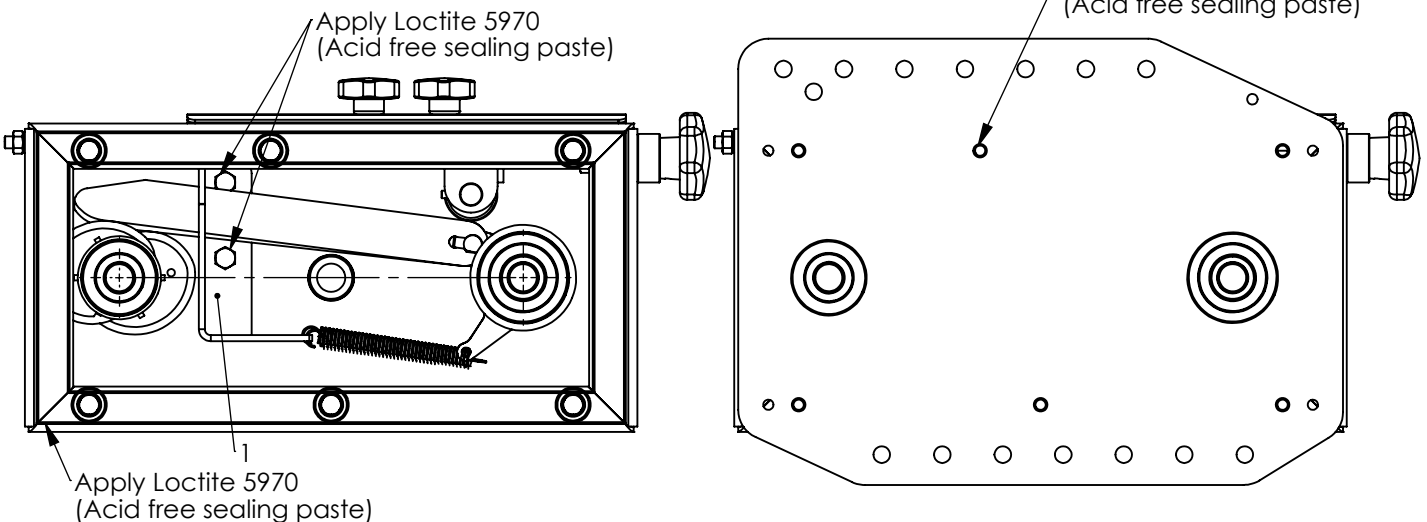



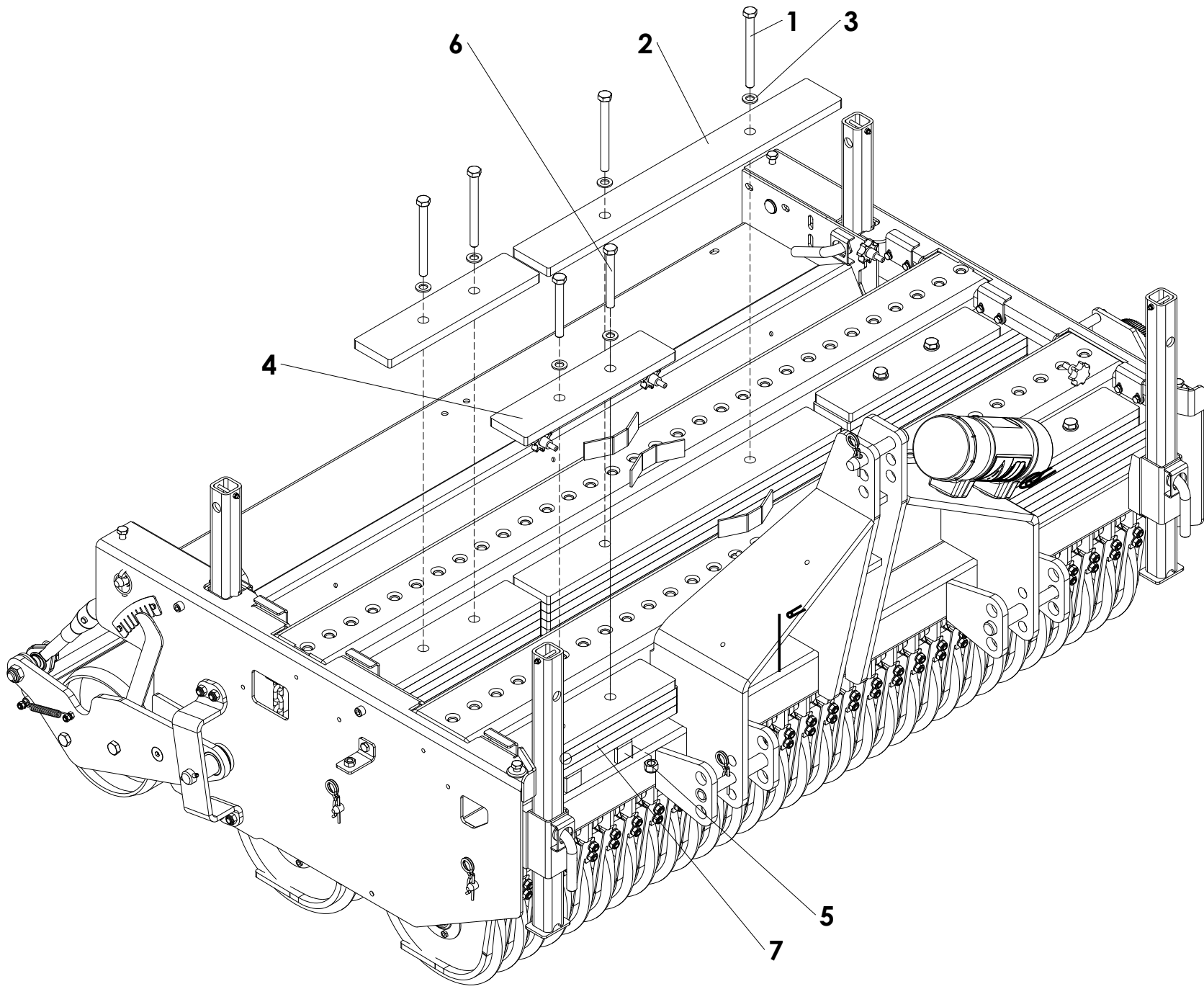

Section inner ballast

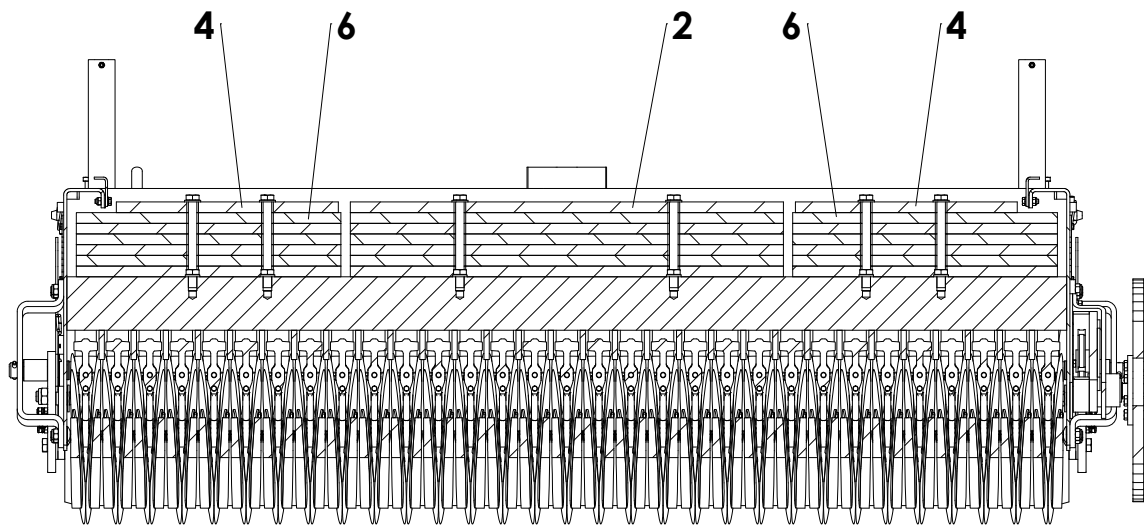

Section outer ballast

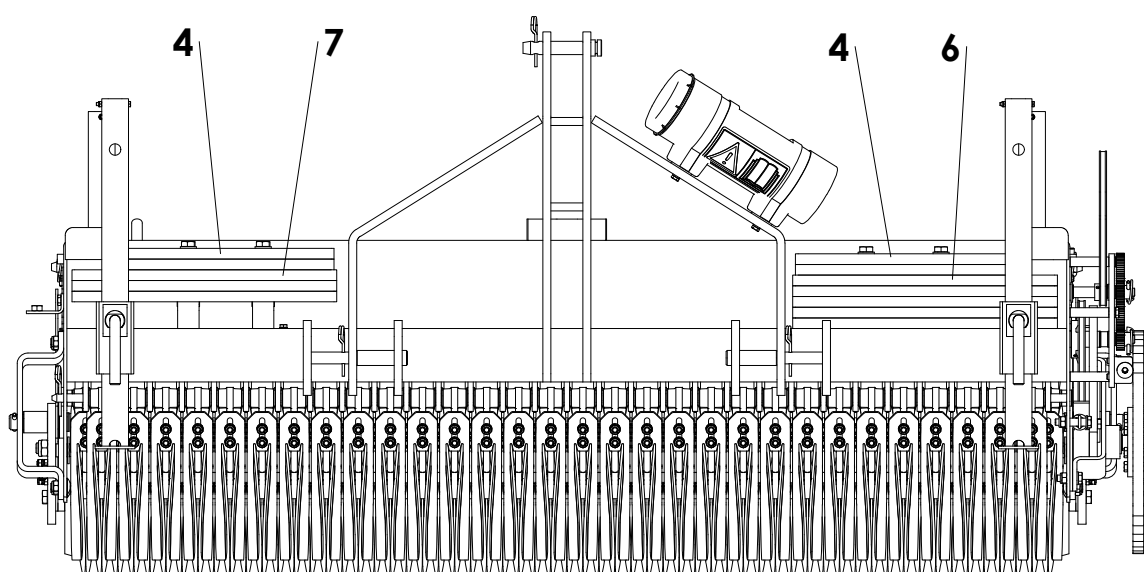



ITEM	PART NUMBER	DESCRIPTION	REMARKS	QUA OS1430	QUA OS1830	QUA OS230
1	802.161.700	Bolt M16 x 170 - ISO 4014		8	8	8
2	464.207.700	Ballast plater center		7	7	7
3	864.160.030	Washer M16 - ISO 7089		10	10	10
4	464.204.250	Ballast plate side 1830		0	6	0
	464.202.200	Ballast plate side 1430		6	0	0
	464.206.350	Ballast plate side 2230		0	0	6
5	830.160.160	Self Lock Nut M16 - ISO 10511		10	10	10
6	802.161.300	Bolt M16 x 130 - ISO 4014		2	2	2
7	464.205.300	Ballast plate rear 1830		0	18	0
	464.203.300	Ballast plate rear 1430		18	0	0
	464.207.400	Ballast plate rear 2230		0	0	18
	222.140.006	Weight kit		1	0	0
	222.180.006	weight kit		0	1	0
	222.220.006	Weight kit		0	0	1

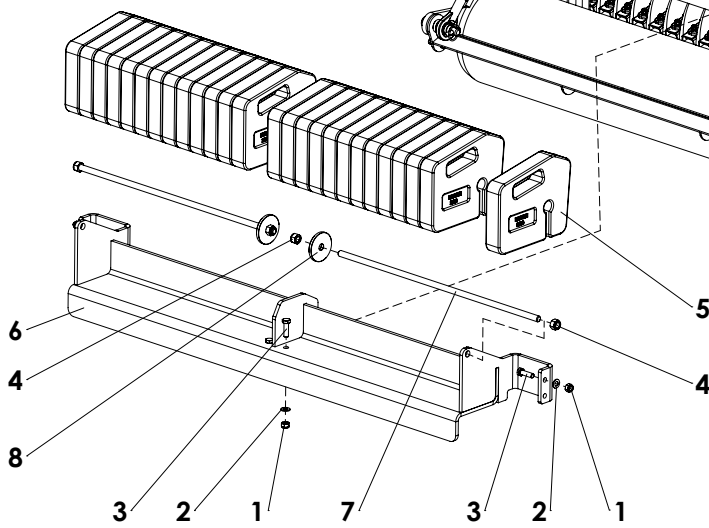
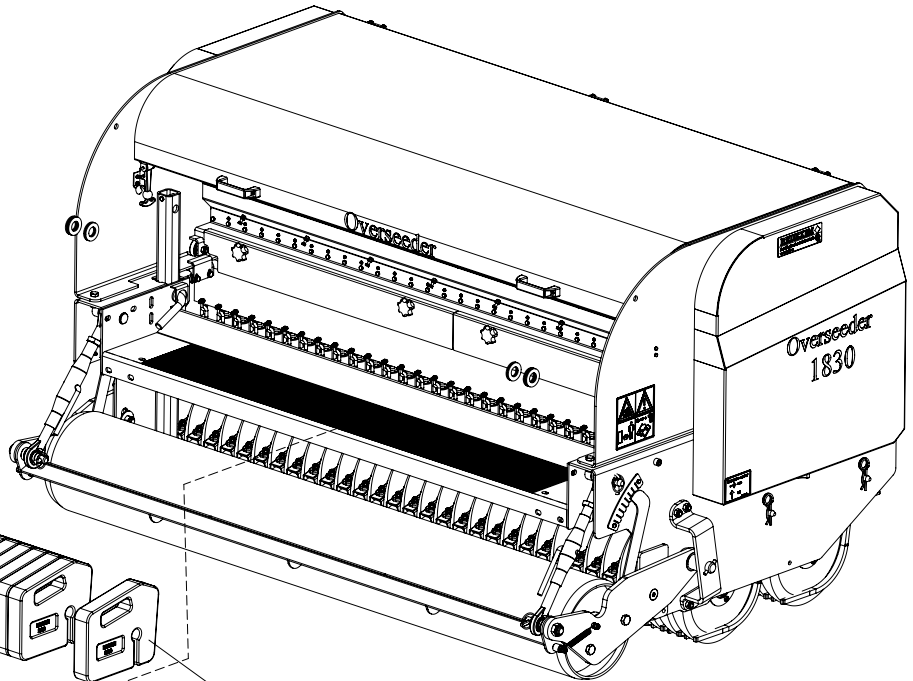
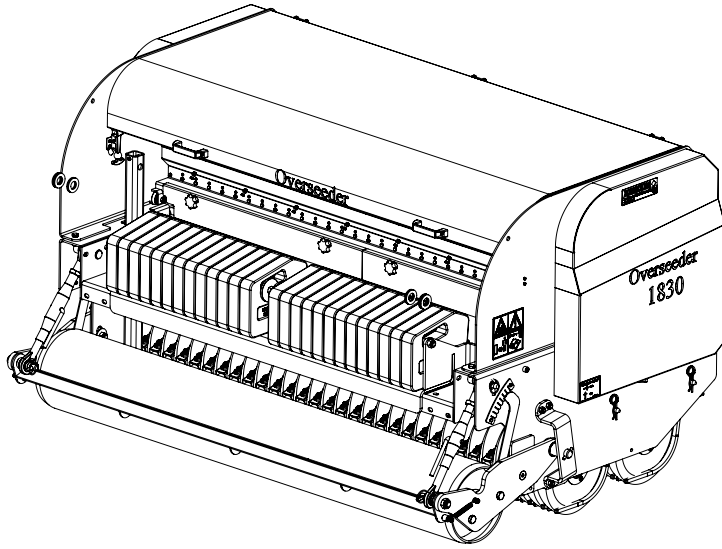

Redexim Weight kit Overseeder 1430A - 1830A -2230A Page 16 Code 1912

ITEM	PART NUMBER	DESCRIPTION	REMARKS	QUA OS1430	QUA OS1830	QUA OS2230
1	830.120.120	Self Lock Nut M12 - ISO 10511		8	8	8
2	864.120.030	Washer M12 - ISO 7089		4	4	4
3	804.120.400	Bolt M12 x 40 - ISO 4017		4	4	4
4	830.160.160	Self Lock Nut M16 - ISO 10511		4	4	4
5	492.502.800	Weight 20kg		16	26	34
6	494.167.017	Ballast frame Overseeder 1830	OS1830	0	1	0
	494.126.020	Ballast frame Overseeder 1430	OS1430	1	0	0
	494.202.020	Ballast frame Overseeder 2230	OS2230	0	0	1
7	416.167.200	Threaded rod M16x720	OS1830	0	1	0
	416.164.500	Threaded rod M16	OS1430	1	0	0
	416.169.200	Threaded rod M16	OS2230	0	0	1
8	402.170.080	Ring Ø80/Ø17 d=8		2	2	2
	222.140.004	Weight kit	OS1430	1	0	0
	222.180.004	Weight kit	OS1830	0	1	0
	222.220.004	Weight kit	OS2230	0	0	1

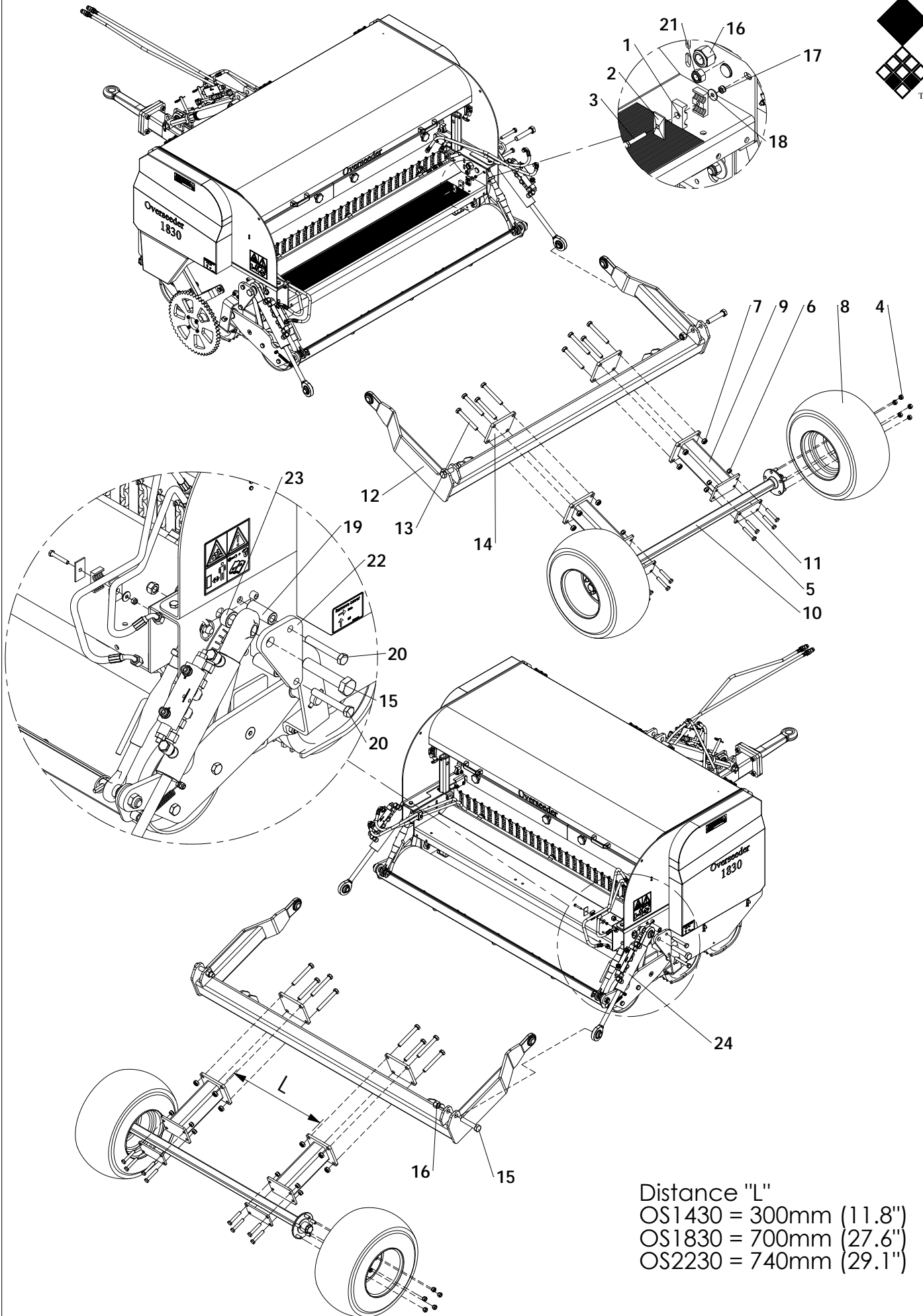
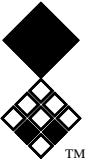

Distance "L"  
 OS1430 = 300mm (11.8")  
 OS1830 = 700mm (27.6")  
 OS2230 = 740mm (29.1")

ITEM	PART NUMBER	DESCRIPTION	REMARKS	QUA OS1430	QUA OS1830	QUA OS2230
1	547.150.150	Hose clamp double 15mm		4	4	4
2	547.300.510	Cover plate hose clamp 2x15 - 2x18		2	2	2
3	802.080.500	Bolt M8 x 50 - ISO 4014		2	2	2
4	844.160.160	Wheel Nut M16		10	10	10
5	802.160.900	Bolt M16 x 90 - ISO 4014		8	8	8
6	830.160.160	Self Lock Nut M16 - ISO 10511		8	8	8
7	830.200.200	Self Lock Nut M20 Din 985 h=17		8	8	8
8	511.660.305	Wheel 26x12 inch complete		2	2	2
9	462.150.375	Axle spacer		2	2	2
10	519.050.915	Wheel shaft 50x50 L=1500	OS1830 + OS2230	0	1	1
	494.117.017	Wheel shaft 50x50 L=1100	OS1430	1	0	0
11	464.102.000	Clamp strip		2	2	2
12	494.215.082	Bogy frame Overseeder 1830		0	1	0
	494.173.082	Bogy frame Overseeder 1430		1	0	0
	494.257.082	Bogy frame Overseeder 2230		0	0	1
13	802.201.600	Bolt M20 x 160 - ISO 4014		8	8	8
14	468.152.006	Mounting plate		2	2	2
15	808.010.051	Hex Bolt 1"-8x5" UNC - ANSI B18.2.1		4	4	4
16	838.010.220	Self Lock Nut 1 inch UNC - DIN 985		4	4	4
17	830.080.080	Self Lock Nut M8 - ISO 10511		2	2	2
18	864.080.024	Large washer M8 - DIN 9021		2	2	2
19	406.170.710	Distance bush Ø30/Ø16.5 L=71		4	4	4
20	802.161.100	Bolt M16 x 110 - ISO 4014		4	4	4
21	830.160.160	Self Lock Nut M16 - ISO 10511		4	4	4
22	468.152.130	Cylinder contra plate		2	2	2
23	406.260.200	Distance bush Ø40/Ø26 L=20		2	2	2
24	534.250.493	Hydraulic cylinder 25-50 Stroke=200		2	2	2
	222.140.002	Double Disc Overseeder 1430 Bogy kit				
	222.180.002	Double Disc Overseeder 1830 Bogy kit				
	222.220.002	Double Disc Overseeder 2230 Bogy kit				

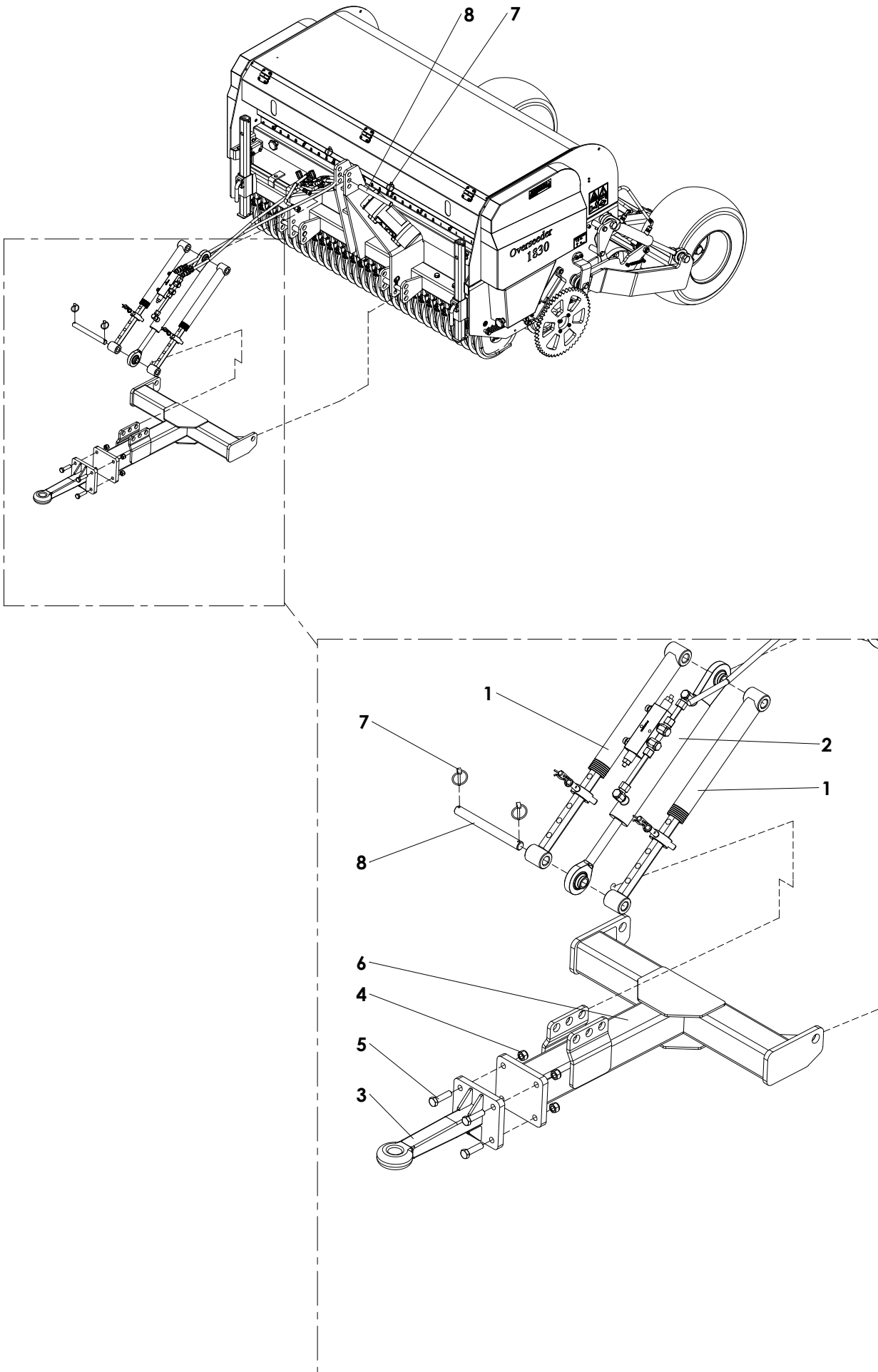

ITEM	PART NUMBER	DESCRIPTION	REMARKS	QUA OS1430	QUA OS1830	QUA OS2230
1		Block cylinder assembly	Page 18	2	2	2
2	534.250.592	Cylinder assembly	Page 20	1	1	1
3	470.203.900	Towing hitch		1	1	1
4	830.160.160	Self Lock Nut M16 - ISO 10511		4	4	4
5	802.160.600	Bolt M16 x 60 - ISO 4014		4	4	4
6	462.217.812	Drawbar Bogy		1	1	1
7	523.060.320	Linch pin Ø6		4	4	4
8	414.252.500	Link pin		2	2	2

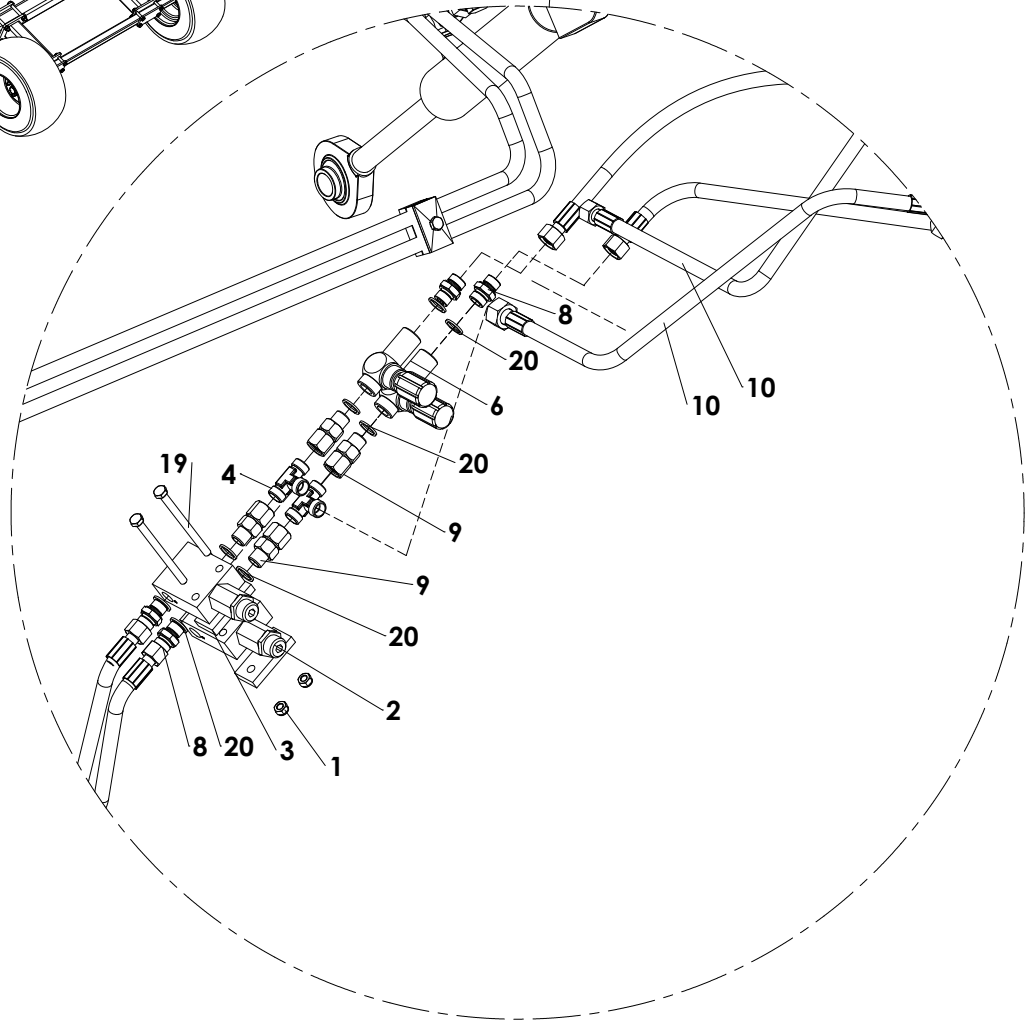
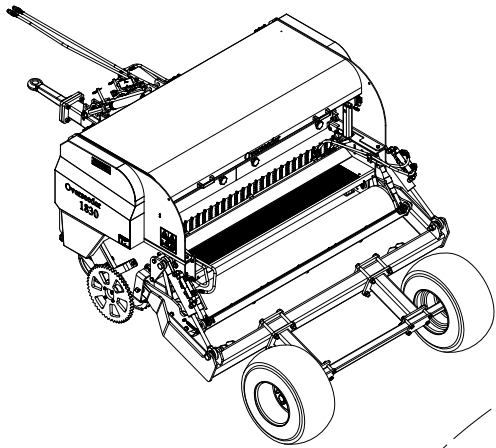
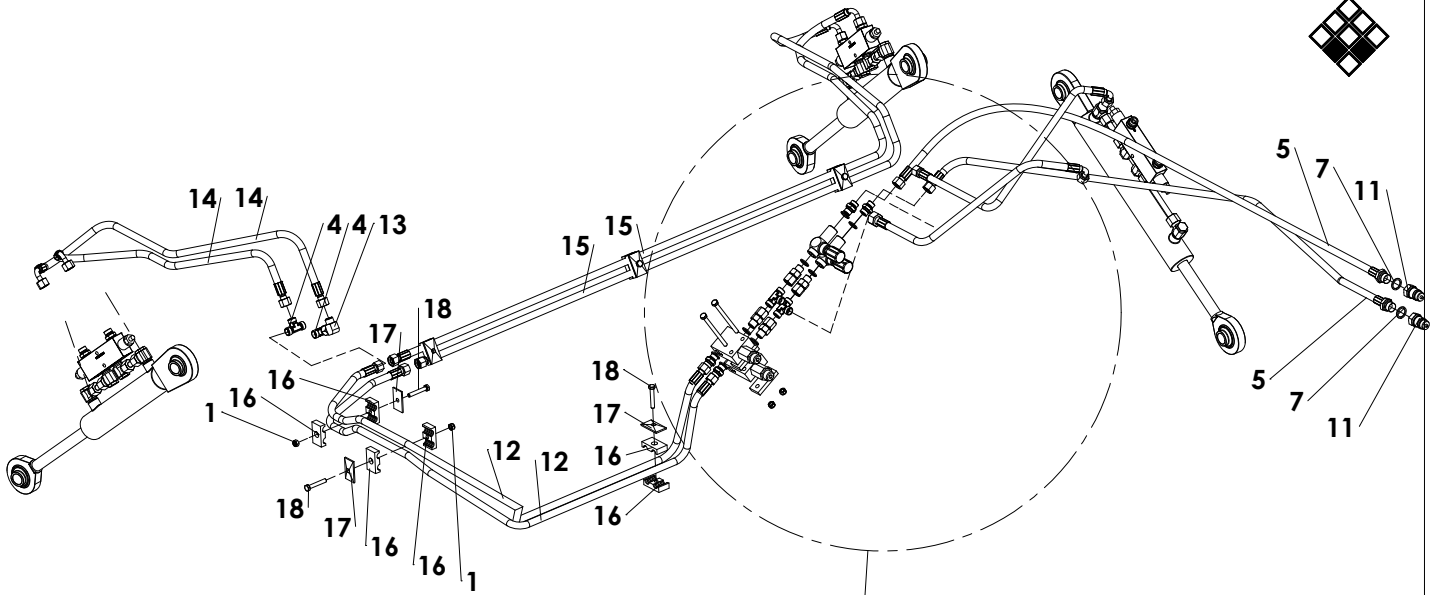



ITEM	PART NUMBER	DESCRIPTION	REMARKS	QUA OS1430	QUA OS1830	QUA OS2230
1	830.080.080	Self Lock Nut M8 - ISO 10511		7	7	7
2	535.300.740	Sequence valve		2	2	2
3	464.100.650	Strip		2	2	2
4	544.124.125	T-Connector 12x12x12		4	4	4
5	541.173.000	Hose NSK10-3/8" TL=2500 PGLO1018 +PN108		2	2	2
6	536.300.500	Flow reducer 3/8" FPU05001		2	2	2
7	874.210.020	Copper washer 1_2		2	2	2
8	544.170.120	Nipple BSP 3_8" x pipe 12 (M18)		4	4	4
9	543.170.122	Joint Connector Straight 3/8" x Ø12 Prem.		4	4	4
10	541.170.830	Hose NSK10-3/8" TL=830 PGLO101890 + PGLO1018		2	2	2
11	545.210.800	Quick connector male 1/2"		2	2	2
12	541.171.610	Hose NSK10-3/8" TL=1610 2xPGLO1018	OS1830	0	2	0
	541.171.410	Hose NSK10-3/8" TL=1410 2xPGLO1018	OS1430	2	0	0
	541.171.810	Hose NSK10-3/8" TL=1810 2xPGLO1018	OS2230	0	0	2
13	544.120.361	L-Connector		1	1	1
14	541.170.950	Hose NSK10-3/8" TL=950 PGLO1018 + PGLO101890		2	2	2
15	541.172.350	Hose NSK10-3/8" TL=2350 PGLO101890 + PGLO1018	OS1830	0	2	0
	541.171.950	Hose NSK10-3/8" TL=1950 PGLO101890 + PGLO1018	OS1430	2	0	0
	541.172.770	Hose NSK10-3/8" TL=2770 PGLO101890 + PGLO1018	OS2230	0	0	2
16	547.150.150	Hose clamp double 15mm		12	12	12
17	547.300.510	Cover plate hose clamp		6	6	6
18	802.080.500	Bolt M8 x 50 - ISO 4014		6	6	6
19	802.081.100	Bolt M8 x 110 - ISO 4014		2	2	2
20	874.170.020	Copper washer 3_8		8	8	8

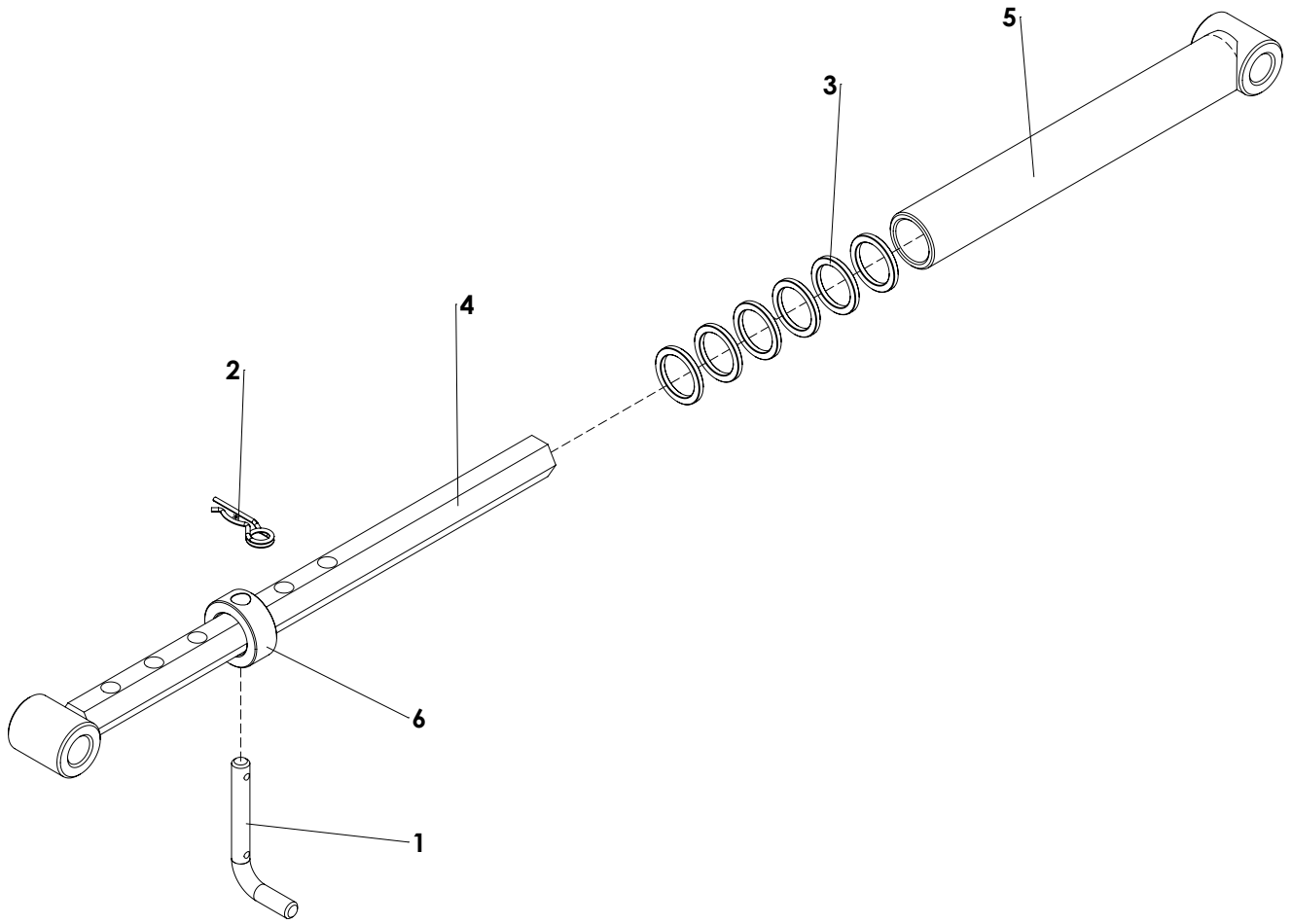

ITEM	PART NUMBER	DESCRIPTION	REMARKS	QUA
1	424.151.280	Lock pin	Qua per machine	2
2	523.030.750	R-Clip Round 3, DIN 11024	Qua per machine	2
3	406.390.050	Distance bush Ø51/Ø38.4 L=5	Qua per machine	12
4	474.324.504	Hex stop inner		1
5	478.513.502	Hex stop outer		1
6	402.380.250	Bush		1

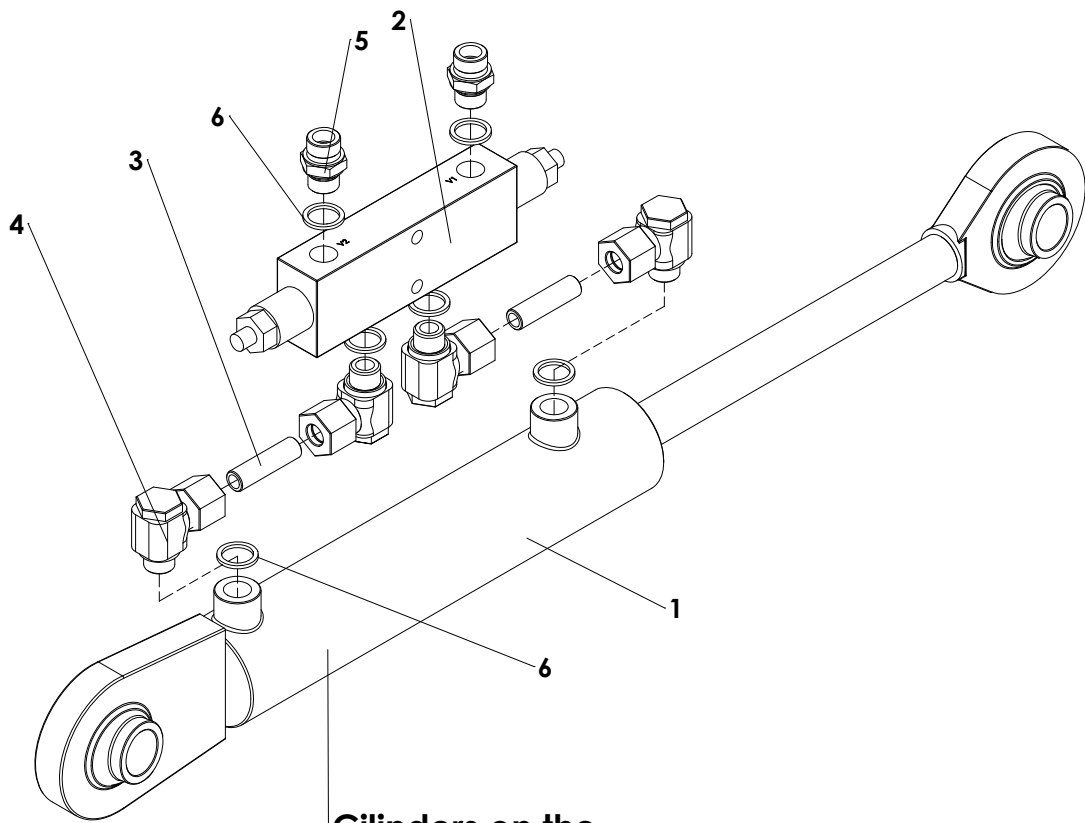
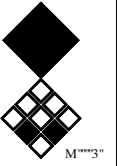

**Cilinders on the  
back side of the Overseeder**

ITEM	PART NUMBER	DESCRIPTION	REMARKS	QUA
1	534.250.492	Hydraulic cylinder 25-50 Stroke=200		1
2	536.502.100	Double equalising valve 3/8"		1
3	542.120.045	Tube 12 x 45		2
4	544.123.122	L-connector G3/8-12mm		4
5	544.170.120	Nipple BSP 3_8" x pipe 12 (M18)		2
6	874.170.020	Copper washer 3_8		6
	534.250.493	Hydraulic cylinder	All items but 2x #5 and 2x #6 excluded	



**3-point cilinder on the tractor side of the Overseeder**

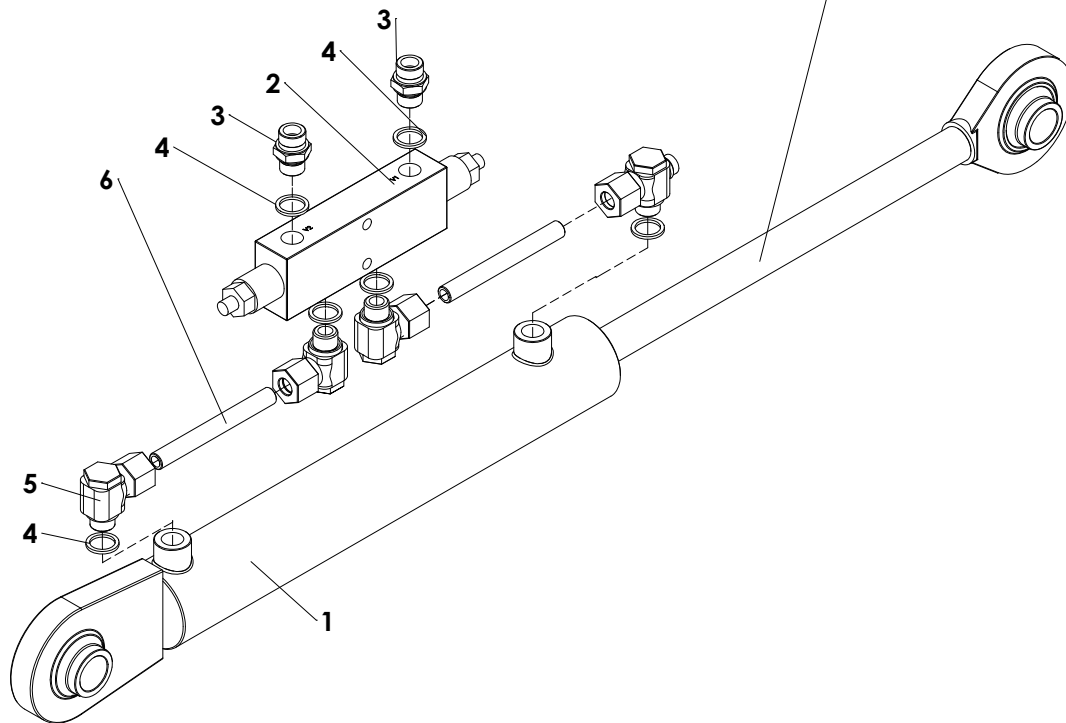

ITEM	PART NUMBER	DESCRIPTION	REMARKS	QUA
1	534.250.591	Hydraulic cylinder 25-50, Stroke=300		1
2	536.502.100	Double equalising valve 3/8"		1
3	544.170.120	Nipple BSP 3_8" x pipe 12 (M18)		2
4	874.170.020	Copper washer 3_8		6
5	544.123.122	L-connector G3/8-12mm		4
6	542.120.135	Tube 12x135		2
	534.250.592	Cylinder assembly front cilinder	All items but 2x #3 and 2x #4 excluded	

